

R S.A.T.

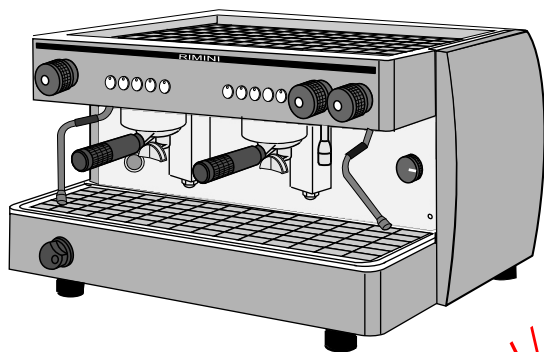

GAMA Standard / Ottima / Genova / Compac / XL

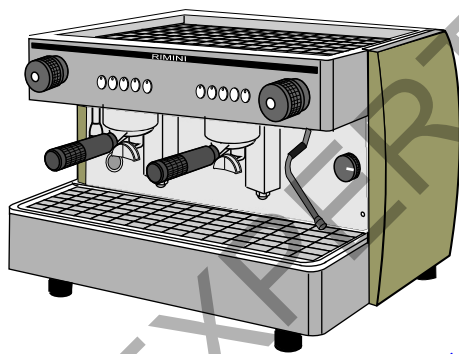

RANGE Standard / Ottima / Genova / Compac / XL

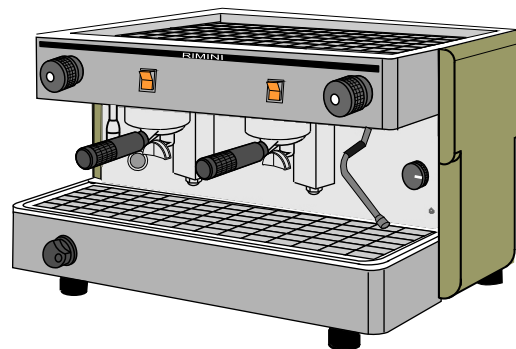

MANUAL DESPIECE SPARE PARTS

INDICE

INDEX

PAG. 1 < 7-,	CARROCERIA Y COMPLEMENTOS (Nuevo) BODY WORK & COMPLEMENTS N (New)
PAG. 1 < 7-,	CARROCERIA Y COMPLEMENTOS (Anterior) BODY WORK & COMPLEMENTS (Former)
PAG. 2 < 7-,	SISTEMA HIDRÁULICO HYDRAULIC SYSTEM
PAG. 2 < 7-,	SISTEMA HIDRÁULICO PULSER (OTTIMA) HYDRAULIC SYSTEM SEMIAUT. (OTTIMA)
PAG. 2 < 7-,	SISTEMA HIDRÁULICO ELECT. (OTTIMA) HYDRAULIC SYSTEM AUTOMATIC (OTTIMA)
PAG. 3 < 7-,	CALDERA Y RACORDERIA BOILER & ACCESSORIES
PAG. 3 < 7-,	CALDERA Y RACORDERIA PULSER (OTTIMA) BOILER & ACCESSORIES SEMIAUT. (OTTIMA)
PAG. 3 < 7-,	CALDERA Y RACORDERIA ELECT. (OTTIMA) BOILER & ACCESSORIES AUTOMATIC (OTTIMA)
PAG. 4 < 7-,	GRIFOS SERVICIO AGUA Y VAPOR HOT WATER & STEAM TAPS
PAG. 5 < 7-,	COMPLEMENTOS ELECTRICOS ELECTRIC – PARTS
PAG. 7 < 7-,	ACCESORIOS ACCESSORIES
PAG. 8 < 7	KIT GAS
PAG. 9 < 7-,	KIT CAPPUCINO

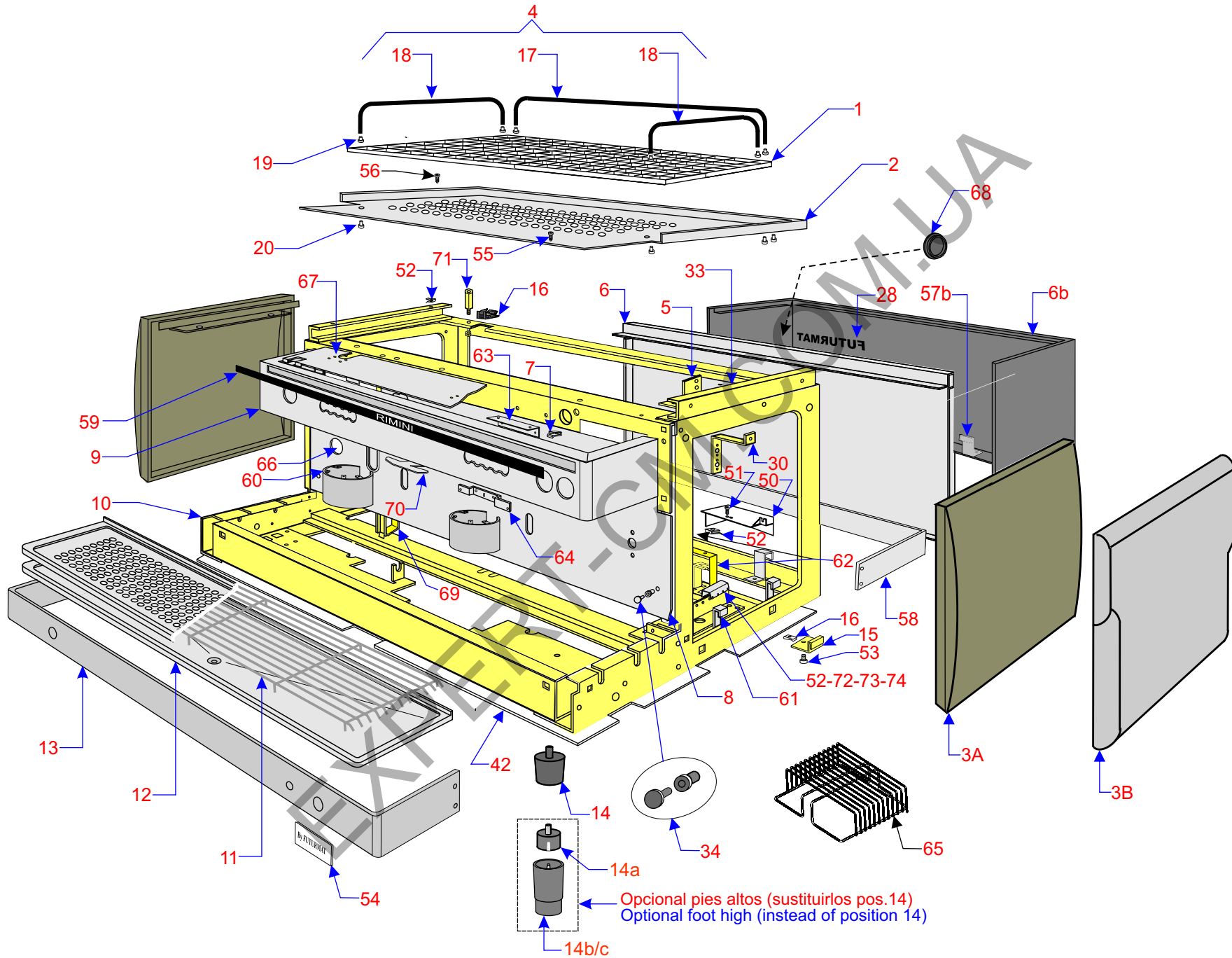

Pos	DENOMINACION	DESCRIPTION	1GR	2GR	OTTIMA 3G	COMPAC	XL
1	Rejilla moplen 414,5x249,5mm	Top cup warmer	2(08437000)			2(08437000)	2(08437000)
1	" " 514,5x332 mm.	" " "		2(08436900)			
2	Bandeja apoyatazas	Upper tray	08267304	08267403	08267502	08267304	08267304
2	" " UL.(E.U.)	" " UL (E.U.)	08267310	08267410			08267310
3A	Lateral color dorado	Lateral colour golden	08439400	08439400		08439400	08439400
3B	" " Gris (G)*(V)	" " Gray (G)*(V)	08439500	08439500			
3B	Lateral color blanco (Nera)	Lateral color White (Nera)		08439560			
3B	" " blanco (Mocay)	" " White (Mocay)		08439520			
4	Kit barandillas	Rails kit	NT0021	NT0022		NT0021	NT0021
5	Soporte presostato	Pressure switch support	08320310	08320310	08320310	08320310	08320320
6	Plancha trasera	Rear plate	08444200	08444300		08444200	08432500
6b	Carrocería (Ottima)	Body word (Ottima)		08319020	08319120		
6b	" (Ottima) Alta	" " (Ottima) Tall		08319030	08319130		
7	Tuerca autorrosc. Fijac.carroc.	Nut	05156807	05156807			
8	Panel S/ Gas S/ nivel	Panel without-gas without-level	08438700	08438800	08438900		
8	" C/ Gas S/ nivel	" With-Gas without-level	08438710	08438810			
8	" S/ Gas C/ nivel	" Without-Gas with-level	08438720	08438820		08440300	08432300
8	" C/ Gas C/ nivel	" With-Gas with-level	08438730	08438830			
8	Panel (Ottima) Alta	Panel (Ottima) Tall		08496800	08496900		
9	Perfil mandos pulser	Front tap semiautomatic	08428300	08428400			
9	" " " 2 grifos vap.	" " " 2 steam taps		08429000			
9	" " " pulser (Ottima)	" semiautomatic (Ottima)		08500800			
9	" " " electrónica	" " electronic	08427400	08427500		08431800	08431800
9	" " " 2 grifos vap.	" " " 2 steam taps		08486300			
9b	" " (Ottima)	" " (Ottima)		08487900	08488000		
10	Cjto chasis	Chassis	08300000	08300100	08300020	08300020	08300020
	" " (Ottima) Alta	" (Ottima) Tall		08460700	08460800		
11	Sobre bandeja	Upper tray	08429500	08429600		08429500	08429500
11b	" " (Ottima)	" " (Ottima)		08444500	08444600		
12	Bandeja desagüe	Drain tray	08429100	08429200	08429300	08429100	08429100
13	Faja chasis S /Gas	Front lower Without-Gas	08160806	08101700			
13	" " lisa	" " smooth	09351600	08351700		08351600	08351600
13	" " color blanco Mocay	" " colour white		08351730			
13	" " C/ Gas inox.	" " With-Gas inox.		08101400			
13	" " " oro	" " " gold		08101420			
13b	" " (Ottima)	" " (Ottima)		08491900	08492000		
13b	" llenado manual	" " manual filling (Ottima)		08500500			
14	Pié de apoyo	Machina foot	07468002	07468002	07468002	07468002	07468002
14a	Pié suplemento	Supplement foot	08396300	08396300	08396300	08396300	08396300
14b	Pié de 80 mm.	Foot 80 mm.	08396400	08396400	08396400	08396400	08396400
14c	Pié de 105 mm.	Foot 105 mm.	08396500	08396500	08396500	08396500	08396500
15	Tope inferior	Fixing nut	08213902	08213902		08213902	
16	Tuerca M.5 Fijac.Tope inferior	Nut	05118500	05118500		05118500	
17	Barandilla superior	Back rail	08273411	08273411		08273411	08273411
18	Barandilla superior lateral	Side rail	08273213	08273213		08273213	08273213
19	Casquillo barandilla	Rail cap	08279705	08279705		08279705	08279705
20	Tornillo CA.E.4,2	Screw	04592101	04592101		04592101	04592101
28	Logo plancha trasera Futurmat	Sticker Futurmat	08441600	08441600		08441600	08441600
28	" " " Gaggia	" Gaggia	08441500	08441500			
28	" " " Visacrem	" Visacrem	08441700	08411700			
30	Soporte termostato	Thermostat support	08196510	08196510	08196510	08196510	08196510
33	Suplem. chasis izq.	Chassis supplement left					08431200
	" " (Ottima)	" " (Ottima) Tall		08431200	08431200		
33	Suplem. Chasis der.	Chassis supplement right					08431300
	" " (Ottima)	" " (Ottima) Tall		08431300	08431300		
34	Remache de plastico	Plastic rivet	08324900	08324900	08324900	08324900	

Pos	DENOMINACION	DESCRIPTION	1GR	2GR	OTTIMA 3Gr	COMPAC	XL
42	Tapa inferior chasis UL (E.U.)	Protector base UL (E.U.)	08372700	08372800			08372700
50	Tapa interruptor	Profile protector switch	08310300	08310300	08310300	08310300	
51	Tornillo	Screw	04591202	04591202	04591202	04591202	04591202
52	Tuerca	Nut	05118400	05118400	05118400	05118400	05118400
53	Tornillo	Screw	04591800	04591800		04591800	
54	Logo By Futurmat	Sticker By Futurmat	08441400	08441400		08441400	08441400
54	" By Gaggia	" By Gaggia	08441300	08441300		08441300	08441300
54	" By Visacrem	" By Visacrem	08441200	08441200		08441200	08441200
54	" By Italcrem	" By Italcrem	08456500	08456500		08456500	08456500
54	" Nera	" Nera	08460300	08460300		08460300	08460300
55	Tornillo autorroscante	Screw	04592101	04592101	04592101	04592101	
56	Tornillo M.4	screw	04591300	04591300	04591300	04591300	04591300
57b	Escuadra suj. Carroc. (Ottima)	Body Word support (Ottima)		08319300	08319300		
58	Faja inferior trasera	Rear cogger seych					08378800
58	" " " (Ottima) Alta	" " " (Ottima) Tall		08378900	08379000		
59	Logo perf. Rimini Pulser S/Nivel	Sticker Rimini semia. Without-	08430150	08430250			
59	" " " " C/Nivel	" " " With-level	08430100	08430200			
59	" " Rimini Electronica	" Rimini Automatic	08429900	08430000		08441000	08441000
59	" " Bianca	" Bianca		08430040			
59	" " Nera Pulser S/ Nivel	" Nera semiaut. Without-	08430160	08430250			
59	" " " " C/ Nivel	" " " With-level	08430110	08430210			
59	" " Nera Electronica	" Nera automatic	08429910	08430010			
59b	" " electrónica (Ottima)	" automatic (Ottima)		08488200	08488300		
59b	" " pulser (Ottima)	" semiautomatic (Ottima)		08500100			
60	Cubregrupos	Group cover	08427100	08427100	08427100	08427100	08427100
61	Escuadra tope	Stop tray					08432600
62	SopORTE caldera	Tank support					08431400
63	Suplemento superior	Upper supplement					08432000
64	" inferior	Lower					08431900
65	Suplemen, sobre bandeja	Upper tray supplement					08439600
65	" " " (Ottima) Alta	" " " (Ottima) Tall		08502200	08502200		
66	Protector panel (Manómetro)	Panel protector (Pressure gauge)	08433900	08433900	08439900	08439900	08439900
67	Protector grupos UL (E.U.)	Groups protector UL (E.U.)	08436300	08436400			08436310
68	Tapón regulación bomba	Rubber cap (Pump regulation)		08494900	08494900		
69	SopORTE electroválvula (Ottima)	Solenoid valve support (Ottima)		08489700	08489700		
69	Tornillo M.4 x 8 inox.	Screw		09000061	09000061		
69	Arandela dentada	Washer		04982100	04982100		
70	SopORTE perfil gr. (Ottima) Alta	Front tap support (Ottima) Tall			08500300		
71	Distancial carroc. (Ottima) Alta	Spacer screw exag. (Ottima) Tall		08502100	08502100		
72	SopORTE regleta (115 V.)	Terminal support (115 V.)	09000265	09000265	09000265	09000265	09000265
73	Tornillo M.4 x 8	Screw M.4 x 8	04591500	04591500	04591500	04591500	04591500
74	Tornillo M.4 x 25	Screw M.4 x 25	04592000	04592000	04592000	04591500	04591500

(*) Especificar marca (*) Model specific



NOTA: Las piezas con la posición (G)
 Pertenecen al modelo **GENOVA**

The parts marked with (G) are for
GENOVA model

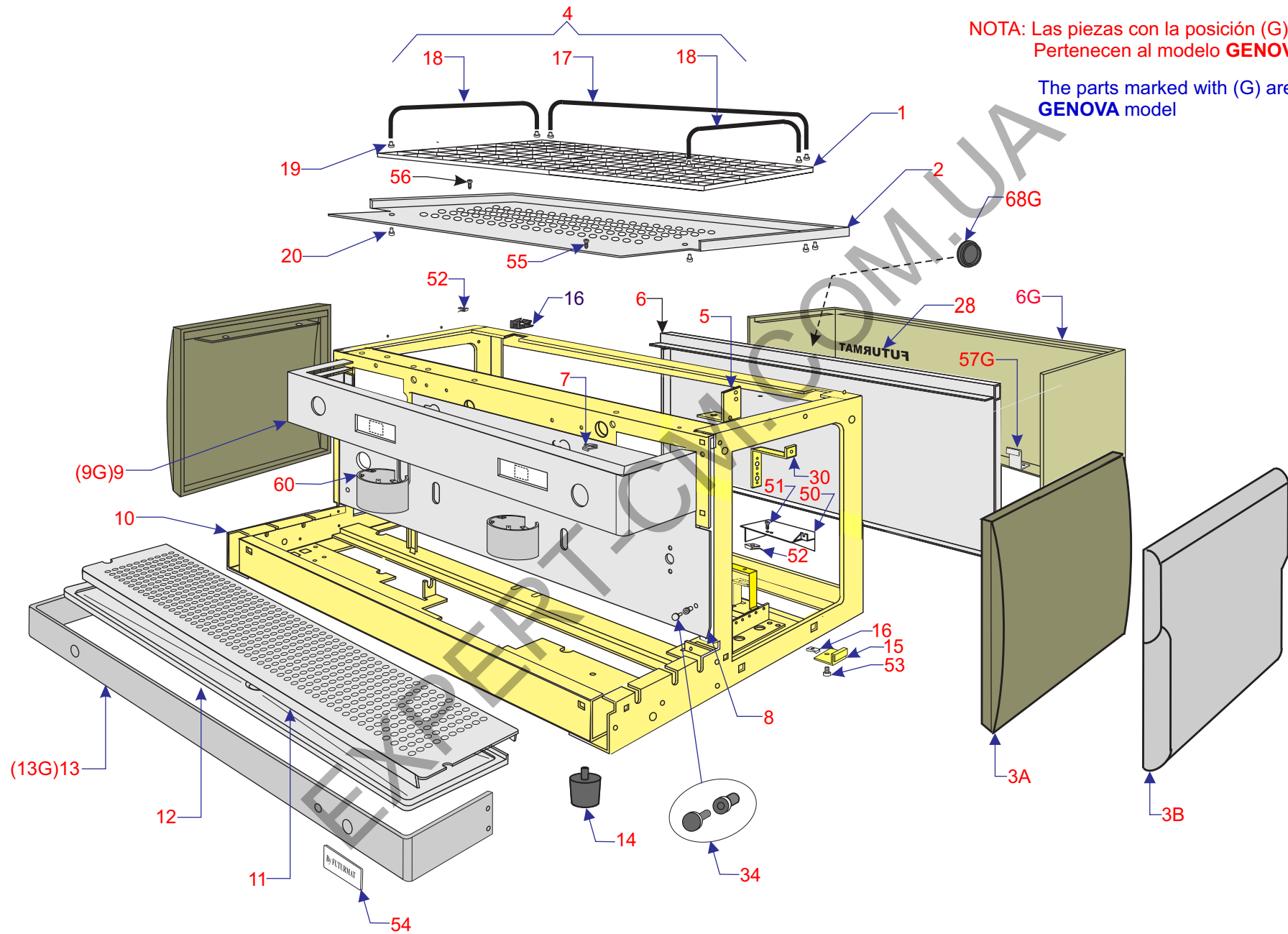

Pos	DENOMINACION	DESCRIPTION	Stand. 1GR	Stand. 2GR	COMPAC
1	Rejilla moplen 414.5 x 249.5 mm.	Top cup warmer	2(08437000)		2(08437000)
1	414,5 x 332 mm.			2(08436900)	
2	Bandeja apoyatazas	Upper tray	08267304	008267403	08267304
3A	Lateral Gris claro (F)*	Lateral Gray (F)	08280604	08265209	08280604
3A	Rojo (M)*	Red (M)	08287302	08265001	
3A	Verde (Novell)	Green (Novell)		08326300	
3A	Gris oscuro (Tenco)	Gray (Tenco)		08292900	
3A	Gris oscuro (Eunasa)	Gray (Eunasa)		08305100	
3A	Gris claro (Ariete Italia)	Gray (Ariete italia)		08285306	
3B	Plata (G)*(V) (Ital. Nera)	Silver (G)(V)(Ital. nera)	08271900	08271900	08271900
3B	Gris oscuro (I)*	Gray (I)	08272007	08272007	
3B	Azul (Castel)	Blue (Castel)		08363700	
4	Kit barandillas	Rails kit	NT0021	NT0022	
5	Soporte presostato	Pressure switch support	08320310	08320310	08320310
6	Plancha trasera (F)* (G)* (I)*	Rear plate (F)* (G)* (I)*	08268104	08268203	08268104
6	(M)*	(M)*	08271603	08271702	
6	(I)* Capri	(I)* Capri		08271405	
6	(Novel) verde	Green (Novel)		08326200	
6G	Carroceria (Genova)	Body work (Genova)		08319000	
6G	Blanca	Whit		08352600	
6G	Rojo	Red		08393300	
7	Tuerca autorrosc. Fijac. Carroc.	Nut	05156807	05156807	
8	Panel S/ Gas	Panel Without-Gas	08438740	08438840	08379600
8	s/ nivel optico	without sight level	08478760	08438860	
8	C/ Gas	Panel With-Gas	08438750	08438850	
8	s/ nivel optico	without sight level	08438770	08438870	
9	Perfil mandos pulser (F)* (G)* (I)*	Front tap semiautomatic (F)* (G)* (I)*	08265704	08265803	
9	(M)*	(M)*	08270209	08270308	
9	(I)* Capri	(I)* Capri		08270001	
9G	(Genova)	(Genova)		08319500	
9G	Blanca	Whit		08352700	
9	Electrónica (F)* (G)* (I)*	electronic (F)* (G)* (I)*	08266108	08266207	
9	(M)*	(M)*	08273906	08274003	
9	(I)* Capri	(I)* Capri		08273708	
9	(Novel)	(Novel)		08325900	
9G	(Genova)	(Genova)		08319800	
9G	Blanca	whit		08352800	
9	(Compac)	(Compac)			08379800
9	C/ cappuccino Inox.*	With- cappuccino Inox*	08268500		
9	Rojo*	Rojo*	08276305		
10	Cj. Chasis	Chassis	08300000	08300100	08300020
11	Sobre bandeja	Upper tray	08444400	08444500	08444400
12	Bandeja desagüe	Drain tray	08429100	08429200	08429100
13	Faja chasis S/ Gas (F) (G) (I) Inox.*	Front lower Without-Gas (F) (G)	08160806	08101700	
13	s/ taladros	without - drill hole	08351600	08351700	08351600
13	(F) Oro*	(F) Gold		08101710	
13	(M)* Rojo*	(M) Red	08269607	08269706	
13	s/ taladros	without - drill hole	08366800	08360700	
13	(I)* Gris osc.*	(I) Gray		08269409	
13	s/ talad.	without - drill hole		08361300	
13	Novell verde s/ taladros	Green (Novel)		08366900	
13G	(Genova) Pulser	(Genova)		08320100	
13G	Blanca	Whit		08352400	
13G	Faja chasis (Genova) Electronica	Front lower (Genova) electronic		08323700	
13G	Blanca	Whit		08352800	
13	C/ gas (F) (G) (I) Inox.*	With-Gas (F) (G) inox	08321500	08101400	
13	Oro*	Gold		08101420	
13	Rojo*	Red		08282303	
13	Gris Oscuro*	Gray		08286710	
14	Pie de apoyo	Machine foot	07468002	07468002	07468002
15	Tope inferior	Fixing nut	08213902	08213902	08213902
16	Tuerca M.5 fijac. Tope inferior	Nut	05118500	05118500	05118500
17	Barandilla superior	Back rail	08273411	08273411	
18	Barandilla superior lateral	Side rail	08273213	08273213	
19	Casquillo barandilla	Rail cap	08279705	08279705	
20	Tornillo CA.E.4.2	Screw	04592101	04592101	
30	Soporte termostato	Termostat support	08196510	08196510	08196510
34	Remache de plastico	Plastic rivet	08324900	08324900	08324900
50	Tapa interruptor	Profile protector Switch	08310300	08310300	08310300
51	Tornillo	Screw	04591202	04591202	04591202
52	Tuerca	Nut	05118400	05118400	05118400
53	Tornillo M.5	Screw	04591800	04591800	04591800
54	Etiqueta By Italcrem	Sticker By Italcrem	08456500	08456500	
54	By Mairali	By Mairali	08456600	08456600	
54	Capri	Capri	08459800	08459800	
54	Giulietta	Giulietta	08456700	08456700	
55	Tornillo autorrosc.	Screw	04592101	04592101	04592101
56	Tornillo M.4	Screw	04591300	04591300	04591300
57G	Escuadra sujec. Carroc. (Genova)	Body work support (Genova)	08319300	08319300	
60	Cubregrupos	Cover groups	08427100	08427100	08427100
68G	Tapón regulación bomba (Genova)		08494900	08494900	

(*) Especificar marca (*) Model specific

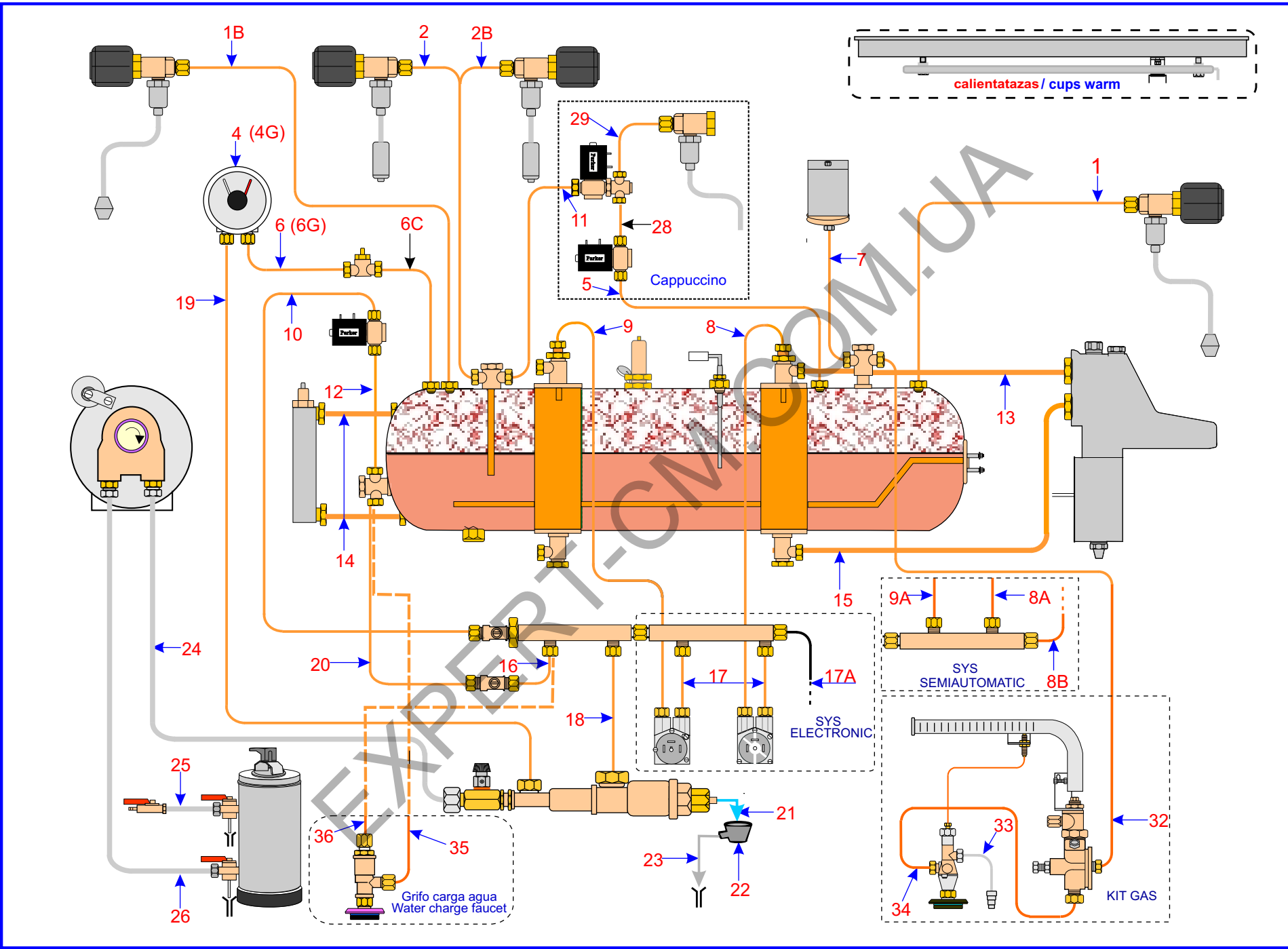

Pos	DENOMINACION	DESCRIPTION	Stand.1GR.	Stand.2GR	COMPAC	XXL
1	Tubo grifo vapor derecho	Tube right steam tap	08362400	08362400	08362400	08432800
1A	" " " " cappuccino	" " " " Cappuccino	08332700			
1B	Tubo grifos vapor izq. (2 vapores)	" " " " left (2 steam)		08362700		
2	Tubo salida agua caliente	Tube water outlet	08362500	08362500	08379500	08432700
2A	" " " " cappuccino	" " " " cappuccino	08362600			
2B	Tubo salida agua cal.der. (2 vapor)	" " " " right (2 steam)		08486400		
4	Manómetro 16 bar	Pressure gauge 16 bar	08130600	08130600	08130600	08130600
4G	" (Genova)	" (Genova)		08323500		
5	Tubo caldera electrov. vapor	Tube steam solenoid tank	08350300	08350300		
6	Tubo manómetro caldera	Tube tank - pressure gauge	08361500	08361500		
6B	" " Válvula compens.	" " " " vacuum valve	08384800	08384800	08380900	08433100
6G	" " " (Genova)	" " " (Genova)		08384810		
6C	Tubo valv. Compensación caldera	Tube tank vacuum valve	08384700	08384700	08380800	08380800
7	Tubo presostato a racord cald	Tube pressure gauge	08354700	08354700		
7B	Tubo presostato a caldera	Tube tank - pressure switch	08151607	08151607	08151607	08151607
8	Tubo contador a T.T. 2º gr.	Tube 2 nd gr. flowmeter		08308300		
8A	Tubo colector a T.T. 2º gr.	Tube 2 nd gr. collector		08313900		
8B	Tubo colector a T.T. 1º gr.	Tube 1 st collector	08346900	08346900		
9	Tubo contador a T.T. 1º gr.	Tube 1 st gr. flowmeter	08347700	08308200	08308200	08433200
9A	Tubo colector a T.T. 1º gr.	Tube 1 st gr. Collector		08313900		
10	Tubo grifo paso a válvula NE.	Tube electric level tap	08309600	08309600	08309600	08309600
11	Tubo electrov. Agua caliente	Tube pressure gauge to fitting	08358900			
12	Tubo electrov. NE a racord	Tube electric level to fitting	08309700	08309700	08309700	08433000
13	Tubo entrada grupo	Tube inlet group	08346700	08511200	08511200	08432100
13	" " 2º Grupo	" " " " Tube 2 nd gr.			08379300	08440600
14	Tubo nivel superior e inferior	Tube level	08312000	08312000		
15	Tubo retorno grupo	Tube group outlet	08346800	08511300	08511300	08511300
15	" " 2º grupo	" " " " Tube 2 nd gr.			08379400	08379400
16	Tubo colector a grifo entrada	Tube collector to tap inlet	08309800	08309800	08309800	08309800
17	Tubo contador a colector	Tube flowmeter collector		08347600	08347600	08347600
17A	Tubo contador a colector	Tube flowmeter collector	08347500			
18	Conjunto válvulas a colector s/ gas	Tube collector valve without - gas	08343900	08343900	08343900	08343900
18	" " " " c/ gas	" " " " with - gas	08363400	08363400		
19	Tubo manómetro red	Tube pump -pressure gauge	08116510	08116510	08116510	08116510
20	Tubo grifo entrada a racord	Tube tap inlet to fitting	08442200	08442200	08442200	08442210
21	Tubo silicona 6 x 9	Tube silicona	67613609063	67613609063	67613609063	67613609063
22	Cubeta desagüe	Drain cup	08478700	08478700	08478700	08478700
23	Tubo desagüe	Outlet pipe	08020703	08020703	08020703	08020703
24	Tubo salida bomba	Tube pump outlet	08341600	08341600	08341600	08341600
25	Tubo entrada agua red	Tube inlet water	0571/050108	0571/050108	0571/050108	0571/050108
26	Tubo entrada bomba	Tube pump inlet	0551/050112	0551/050112	0551/050112	0551/050112
28	Tubo electrov. vapor	Tube steam solenoid	08350500			
29	Tubo elect a grifo cappuccino	Tube tap solenoid cappuccino	08359200			
32	Tubo cald. a automático gas	Tube automatic gas tank	08357900	08357900		
33	Tubo entrada gas	Tube gas inlet	08320900	07514706		
34	Tubo grifo automático gas	Tube gas automatic tap	08321000	08358000		
35	Tubo grifo agua a racord cald.	Tube water tap to tank fitting	08357300	08357300		
36	Tubo colect. grifo carga agua	Tube water inlet collector to tap	08357200	08357200		

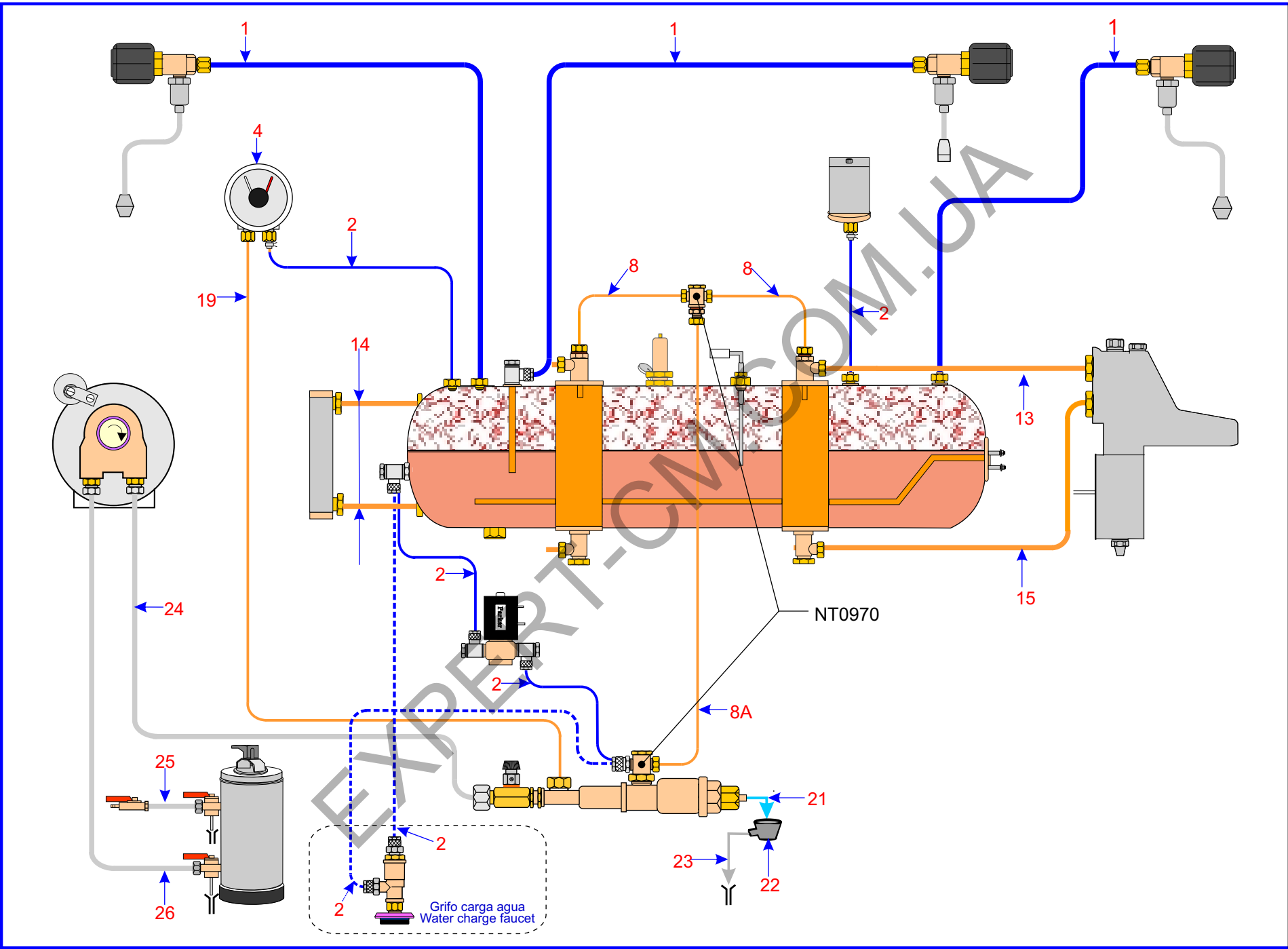

POS.	DENOMINACION	DESCRIPTION	2-GR.
1	tubo teflón 8 x 6 (Mts.)	Teflón tube 8 x 6 (Mts.)	67615608060
2	tubo teflón 6 x 4 (Mts.)	Teflón tube 6 x 4 (Mts)	67615606040
4	Manómetro doble	Pressure gauge double	08130600
8	Tubo inyector	Tube injector	08565400
8A	Tubo cruceta	Tube	08565300
13	Tubo entrada grupo	Tube inlet group	08511200
14	Tubo nivel superior e Inferior	Lower / upper level tube	08312010
15	Tubo retorno grupo	Tube group outlet	08511300
19	Tubo manómetro	Pressure gauge tube	08116510
21	Tubo silicona	Tube silicona	67613609063
22	Cubeta desague	Drain cup	08478700
23	Tubo desañe	Outlet pipe	08020703
24	Tubo salida bomba	Tube puma outlet	08341600
25	Tubo entrada agua red	Tube inlet water	0571/050108
26	Tubo entrada bomba	Tube puma inlet	0551/050112

EXPERT-CM.COM

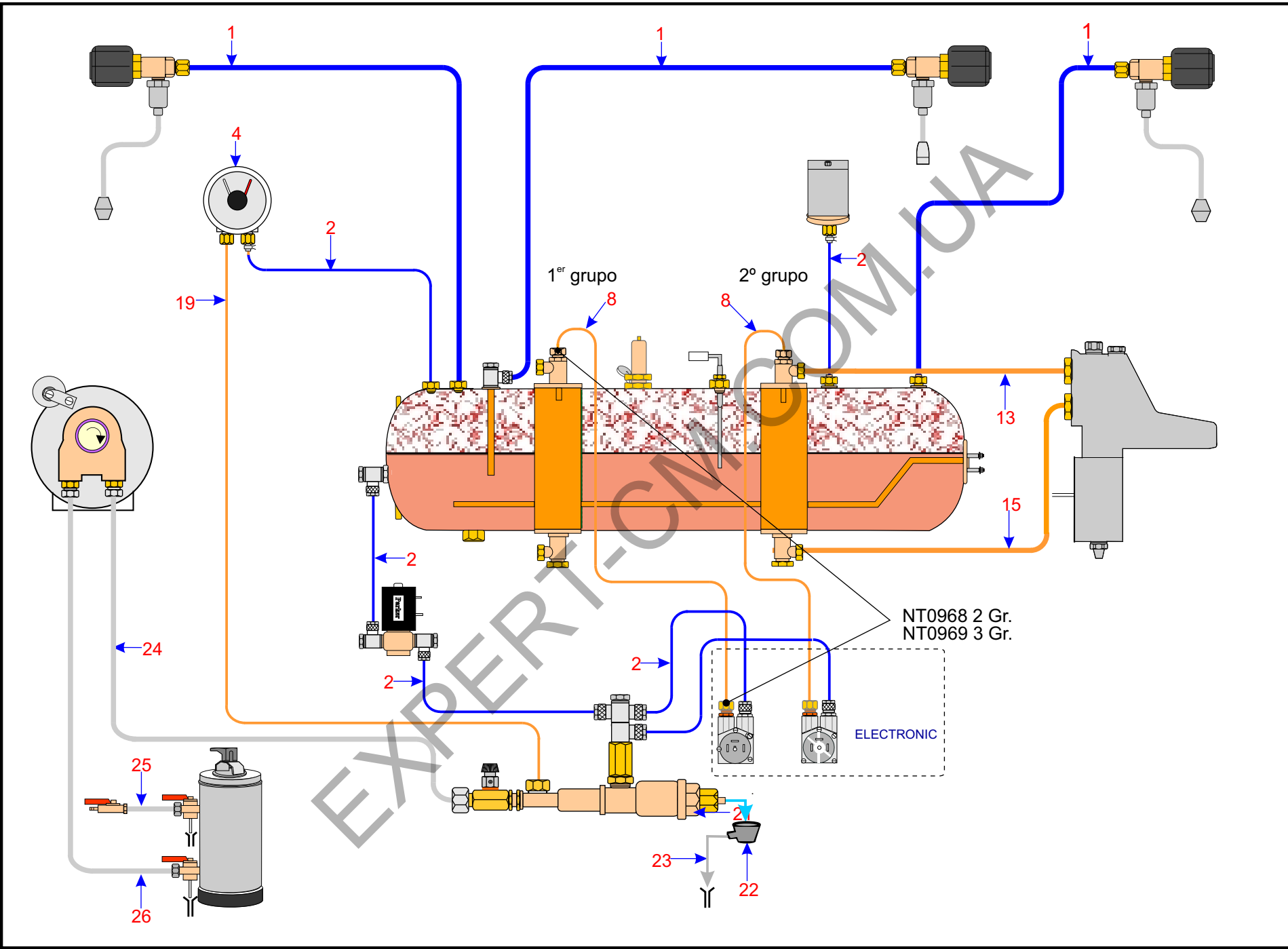

EXPERT-COM.UA

POS.	DENOMINACION	DESCRIPTION	2-3GR.	3GR
1	Tubo teflón 8 x 6 (Mts.)	Teflón tube 8 x 6 (Mts.)	67615608060	
2	Tubo teflón 6 x 4 (Mts.)	Teflón tube 6 x 4 (Mts)	67615606040	
4	Manómetro doble	Pressure gauge double	08130600	
8	Tubo inyector 1er Gr.	Tube injector 1 RD Gr.	08308200	
8	Tubo inyector	Tube injector	08308300	08308400
13	Tubo entrada grupo	Tube inlet group	08511200	
13	“ “ “ Alta	“ “ “ Tall	08463500	
13	“ “ “ 3 ^{ER} Gr. Alta	“ “ “ 3 RD Gr. Tall		08463600
15	Tubo retorno grupo	Tube group outlet	08511300	
15	“ “ “ Alta	“ “ “ Tall	08463700	
19	Tubo manómetro	Pressure gauge tube	08116510	
21	Tubo silicona	Tube silicona	67613609063	
22	Cubeta desague	Drain cup	08478700	
23	Tubo desaüe	Outlet pipe	08020703	
24	Tubo salida bomba	Tube puma outlet	08341600	
25	Tubo entrada agua red	Tube inlet water	0571/050108	
26	Tubo entrada bomba	Tube puma inlet	0551/050112	

EXPERT-CM.COM

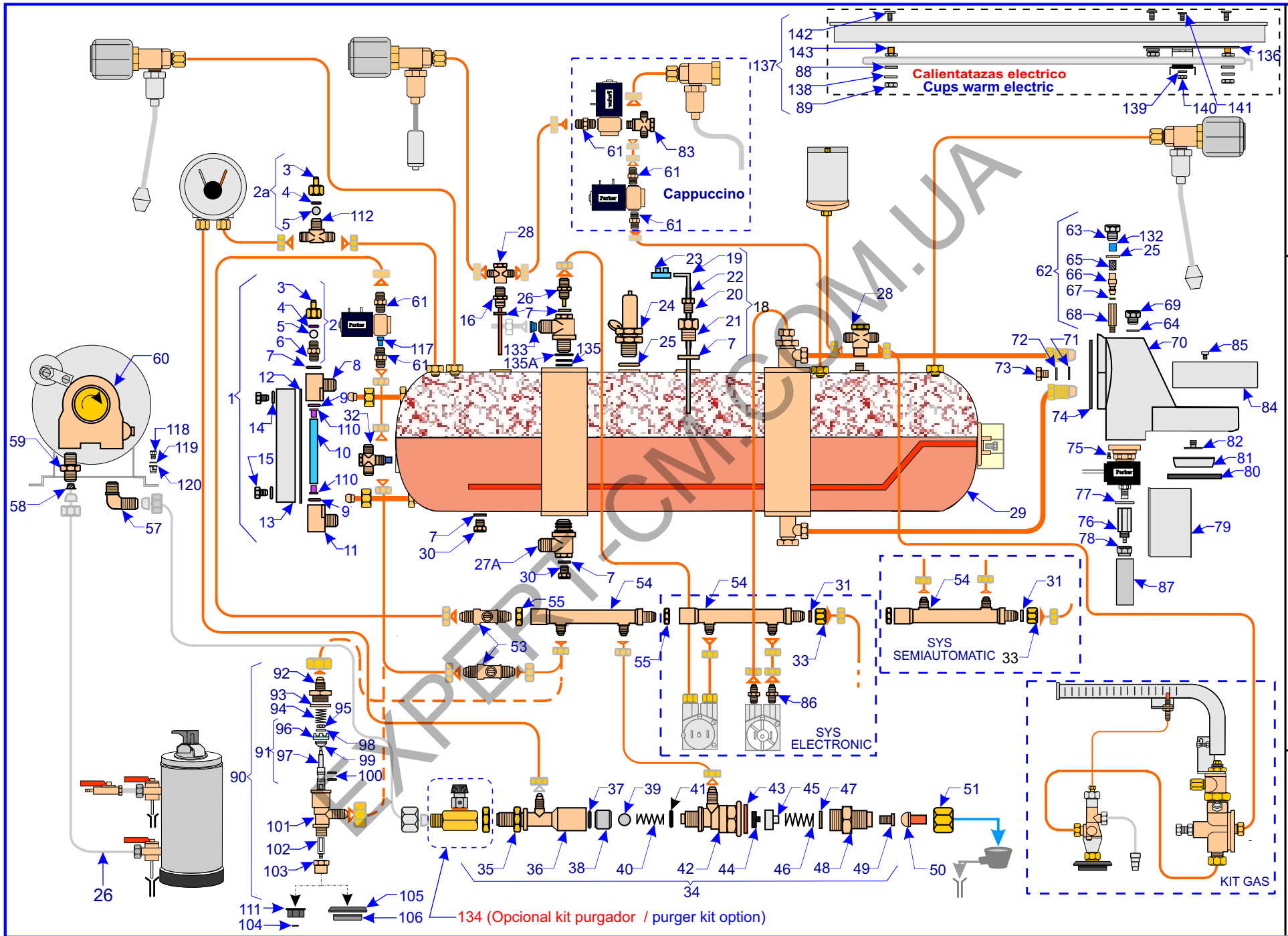

Pos.	DENOMINACION	DESCRIPTION	Stand.1-2-3Gr.	Stand.2-3Gr.	COMPAC	XL
61	Racord	Fitting	07466501		07466501	07466501
61	" UL (E.U.)	" UL (E.U.)	07466519			07466519
62	Kit	Kit	NT 0029		NT 0029	NT 0029
63	Tapón guía muelle	Spring square pin cap	07557200		07557200	07557200
64	Arandela	Washer	07411507		07411507	07411507
65	Filtro	Filter	08298700		08298700	08298700
66	Inyector	Injector	08298800		08298800	08298800
67	Junta tórica	O-ring	0371/040103		0371/040103	0371/040103
68	Columna inyector	Injector column	08299000		08299000	08299000
68	" " UL (E.U.)	" " UL (E.U.)	08299010			08299010
69	Tapón grupo	Group cap	02736403		02736403	02736403
70	Cuerpo grupo	Group body	08427000		08427000	08427000
70	" " UL (E.U.)	" " UL (E.U.)				08427020
71	Arandela	Washer	04333613		04333613	04333613
72	Arandela grower	Washer	04316412		04316412	04316412
73	Tornillo	Screw	04106217		04106217	04106217
74	Junta posterior	Gasket	08305200		08305200	08305200
75	Tornillo	Screw	05194402		05194402	05194402
76	Columna descarga	Outlet column	08426400		08426400	08426400
77	Arandela	Washer	08395300		08395300	08395300
78	Tuerca tapa	Nut	08426500		08426500	08439700
79	Tapa electroválvula	Group solenoid cover	08426600		08426600	08426600
80	Junta portafiltro (standard) 8mm.	Holder gasket (standard) 8mm.	01652809		01652809	01652809
80a	" " (suplementada) 9mm.	" " (supplemented) 9mm.	01160400		01160400	01160400
80b	" " (suplemento) 1mm.	" " (supplement) 1mm.	07158009		07158009	07158009
81	Ducha	Shower	02610004		02610004	02610004
81	" Castel	" Castel	02610020			
82	Rociador de agua	Traed group	02012904		02012904	02012904
82	" " UL (E.U.)	" " UL (E.U.)	02012912			02012912
82	" " Castel	" " Castel	02012920			
83	Racord 1/8 x 1/4	Fitting	08341200			
84	Cubregrupos	Groups cover	08427100		08427100	08427100
85	Tornillo M.4 x 8	Screw	04591300		04591300	04591300
86	Racord	Fitting	02800704		02800704	02800704
86	" UL (E.U.)	" UL (E.U.)	02800712			02800712
87	Tubo descarga agua	Water outlet tube				08433410
88	Arandela plana de 4 inox.	washer		05162400		
89	Tuerca M.4	Nut		04527600		
90	Cj grifo agua red	Compleat water inlet	07466006			
91	Conjunto válvula	Valve complet	07665409			
92	Racord	Fitting	07683709			
93	Arandela	Washer	07412109			
94	Muelle	Spring	10542504			
95	Tuerca	Nut	04527503			
96	Cuerpo válvula	Valve body	03059003			
97	Eje válvula	Valve rod	07665508			
98	Arandela	Washer	04732202			
99	Junta cierre	Gasket	02932200			
100	Junta tórica	O-ring	03070802			
101	Cuerpo grifo	Tap body	07467905			
102	Eje exterior	Rod supplement	07834401			
103	Tuerca 3/8" gas	Nut 3/8" gas	08099400			
104	Adhesivo carga agua	Water inlet fitting	08100000			
105	Embellecedor mando	Handle adorn	08099500			
106	Mando agua	Water handle	08183311			
110	Junta vidrio nivel	Gasket	08367000			
111	Mando agua M- Ital.	Water handle M- Ital.	07678709			
112	Cuerpo válvula compensación	Compesation valve body	08381000		08381000	08381000
112	" " níquel	" " plated	08381010			08381010
117	Reductor entrada agua	Pressure reducer water inlet	08391200		08391200	08391200
118	Tornillo c/exag.	Screw	04522405		04522405	04522405
119	Arandela	Washer	0561/030127		0561/030127	0561/030127
120	Tuerca enjaulada	Nut	0551/030136		0551/030136	0551/030136
132	Tubo teflón 0.012mm.	Teflón 0.012 mm. tube	08441100		08441100	08441100
133	Inyector (Ø interior 4,5 mm.)	Injector (Ø int 4,5 mm.)		08426700	08426700	
133	" " (" " 2,5 mm.)	" " (" " 2,5 mm.)		08426720	08426720	
134	Kit purgador (Opcional)	Purge kit (option)	08447700		08447700	08447700
135	Junta tórica	O-ring	03060500		03060500	03060500
135A	Junta tórica 14 x 1,5	O-ring	08494710		08494710	08494710
136	Soporte termostatos	Thermostat supoort		08519700		
137	Cjto. bandeja calentatazas	Cups warmer tray assembly		08519800		
138	Arandela dentada M.4 inox.	washer		04982100		
139	Arandela dentada M.3 inox.	washer		04982000		
140	Tuerca M.3 inox.	Nut		05126500		
141	Tornillo M.3 x 10 inox.	screw		05161600		
142	Tornillo M.4 x 15 c/ ext.plana	Screw		04596601		
143	Separador	Spacer cupes warm		08350900		

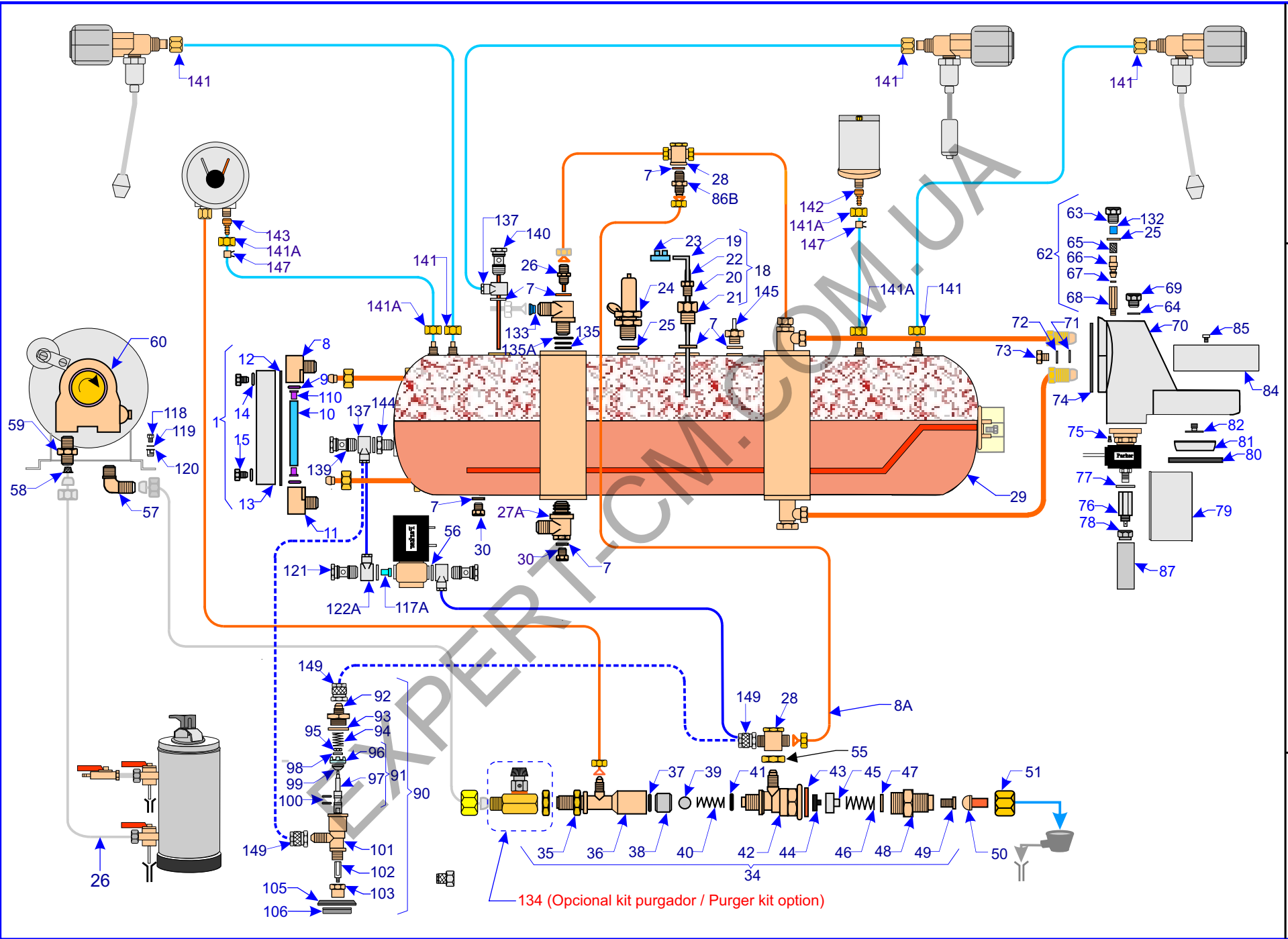

Pos	DENOMINACION	DESCRIPTION	2 GR
1	Cto. Nivel s/ valvula compensación	Compleat level	08501000
7	Arandela de cobre	Washer	01626804
8	Cuerpo nivel superior	Sight gage upper fitting	07966750
9	Junta tórica	O-ring	08291007
10	Vidrio nivel	Sight glass tube	08181703
11	Cuerpo nivel inferior	Sight gage lower fitting	07966750
12	Fondo soporte nivel	Water level sensor	08237000
13	Placa soporte nivel	Sight gage mounting breaket	08156507
14	Arandela dentada	Lock washer	04868300
15	Tornillo c/exagonal	Screw	04104113
18	Conjunto sonda	Level water fitting probe	0441/090816
19	Sonda 123	Sensor 123	0441/090816A
20	Prensa sonda	Sensor press	0441/090816D
21	Racord sonda	Sensor fitting	0441/090816C
22	Aislador sonda	Sensor standard-duty insulator	0441/090816B
23	Regleta conexión	Level probe terminal	07389604
24	Válvula de seguridad	7Pressure relief valve	08074701
25	Arandela	Washer	07412208
26	Racord de entrada (inyector)	Inlet fitting (injector)	08355000
27A	Cjto.Racord tubo termico	Heat exchanger fitting assy	08469920
29A	Caldera sin nivel optico	" without sight level	08491500
	" con nivel optico	" hout sight level	08501600
30	Tapón	Heat exchanger drain plug	00225805
34	Válvula retención / expansión	Check valve / relief valve assy	07843808
35	Tuerca	Nut	04531505
36	Cuerpo válvula retención	Check valve body	07922701
37	Junta tórica	O-ring	07851900
38	Casquillo	Cap	07851801
39	Esfera	Ball	01832005
40	Muelle	Spring	01720606
41	Junta tórica	O-ring	07763204
42	Cuerpo Válvula expansión	Pressure Rilief valve body	07851603
43	Arandela	Washer	08506530
44	Junta cierre	Gasket	01853704
45	Casquillo	Cap	01853803
46	Muelle	Spring	00109108
47	Arandela	Washer	04711701
48	Racord	Fitting	07468101
49	Regulador muelle	Relief Valve orifice	07468408
50	Niple especial	Nipple	08058901
51	Tuerca niple 3/8	Nut	00011502
55	Tuerca 1/4	Nut	04530600
56	Arandela de cobre	Washer	07411600
57	Racord	Fitting	08004418
58	Filtro	Filter	08297900
59	Racord	Fitting	0371/110103
60	Bomba Fluid-o-tech	Pump Fluid-o-tech	07822109
60	" Procon	" Procon	07822109-S
62	Kit	Kit	NT 0029
63	Tapón guía muelle	Spring square pin cap	07557200
64	Arandela	Washer	07411507
65	Filtro	Filter	08298700
66	Inyector	Injector	08298800
67	Junta tórica	O-ring	0371/040103
68	Columna inyector	Injector column	08299000
69	Tapón grupo	Group cap	02736403
70	Cuerpo grupo	Group body	08427000
71	Arandela	Washer	04333613
72	Arandela grower	Washer	04316412
73	Tornillo	Screw	04106217
74	Junta posterior	Gasket	08305200
75	Tornillo	Screw	05194402
76	Columna descarga	Outlet column	08426400
77	Arandela	Washer	08395300
78	Tuerca tapa	Nut	08426500
79	Tapa electroválvula	Group solenoid cover	08426600
80	Junta portafiltro	Holder gasket	01652809

POS.	DENOMINACION	DESCRIPTION	2-3GR.
81	Ducha	Shower	02610004
81	" Castel	" Castel	02610020
82	Rociador de agua	Traed group	02012904
82	" " Castel	" " Castel	02012920
83	Racord 1/8 x 1/4	Fitting	08341200
84	Cubregrupos	Groups cover	08427100
85	Tornillo M.4 x 8	Screw	04591300
90	Cj grifo agua red	Compleat water inlet	07466006
91	Conjunto valvula	Valve complet	07665409
92	Racord	Fitting	07683709
93	Arandela	Washer	07412109
94	Muelle	Spring	10542504
95	Tuerca	Nut	04527503
96	Cuerpo valvula	Valve body	03059003
97	Eje valvula	Valve rod	07665508
98	Arandela	Washer	04732202
99	Junta cierre	Gasket	02932200
100	Junta tórica	O-ring	03070802
101	Cuerpo grifo	Tap body	07467905
102	Eje exterior	Rod supplement	07834401
103	Tuerca 3/8" gas	Nut 3/8" gas	08099400
105	Embellecedor mando	Handle adorn	08099500
106	Mando agua	Water handle	08183311
110	Junta vidrio nivel	gasket	08367000
117A	Reductor entrada agua	Pressure reducer wáter inlet	08505510
118	Tornillo c/exag.	Screw	04522405
119	Arandela	Washer	0561/030127
120	Tuerca enjaulada	Nut	0551/030136
121	Tornillo simpe 1/8"	Screw 1/8"	08504400
122A	Anillo orientable 6/4 1/8" Gas.	Adjustable ring 6/4 1/8" G.	08416010
132	Tubo teflón 0.012mm.	Teflón 0.012 mm. tube	08441100
133	Inyector (Ø interior 4,5 mm.)	Injector (Ø int 4,5 mm.)	08426700
133	" (" " 2,5 mm.)	" (" " 2,5 mm.)	08426720
134	Kit purgador (Opcional)	Purge kit (option)	08447700
135	Junta tórica	O-ring	03060500
135A	Junta torica 14 x 1,5	O-ring 14 x 1,5	08494710
137	Anillo orientable 6/4	Adjustable ring	08462910
137A	Anillo orientable 8/6	Adjustable ring	08462900
139	Clto. Inyector tubo termico	Heat exchanger injector assy	08489500
140	Cjto. Racors pesca	Inlet fitting assy	08489000
141	Tuerca racord 8/6	Fitting nut	08488900
141A	Tuerca racord 6/4	Fitting nut	08488910
142	Espiga presostato	Connection fitting pressure switch	08489300
143	" manómetro	Connection fitting pressure gauge	08489200
144	Racord reductor	Fitting reducing	09000351
145	Válvula antidepresión	Compesation valve body	09000953
147	Abrazadera muelle Ø 6	Clip for tube	08503800
149	Tuerca racord	Fitting nut	08466210

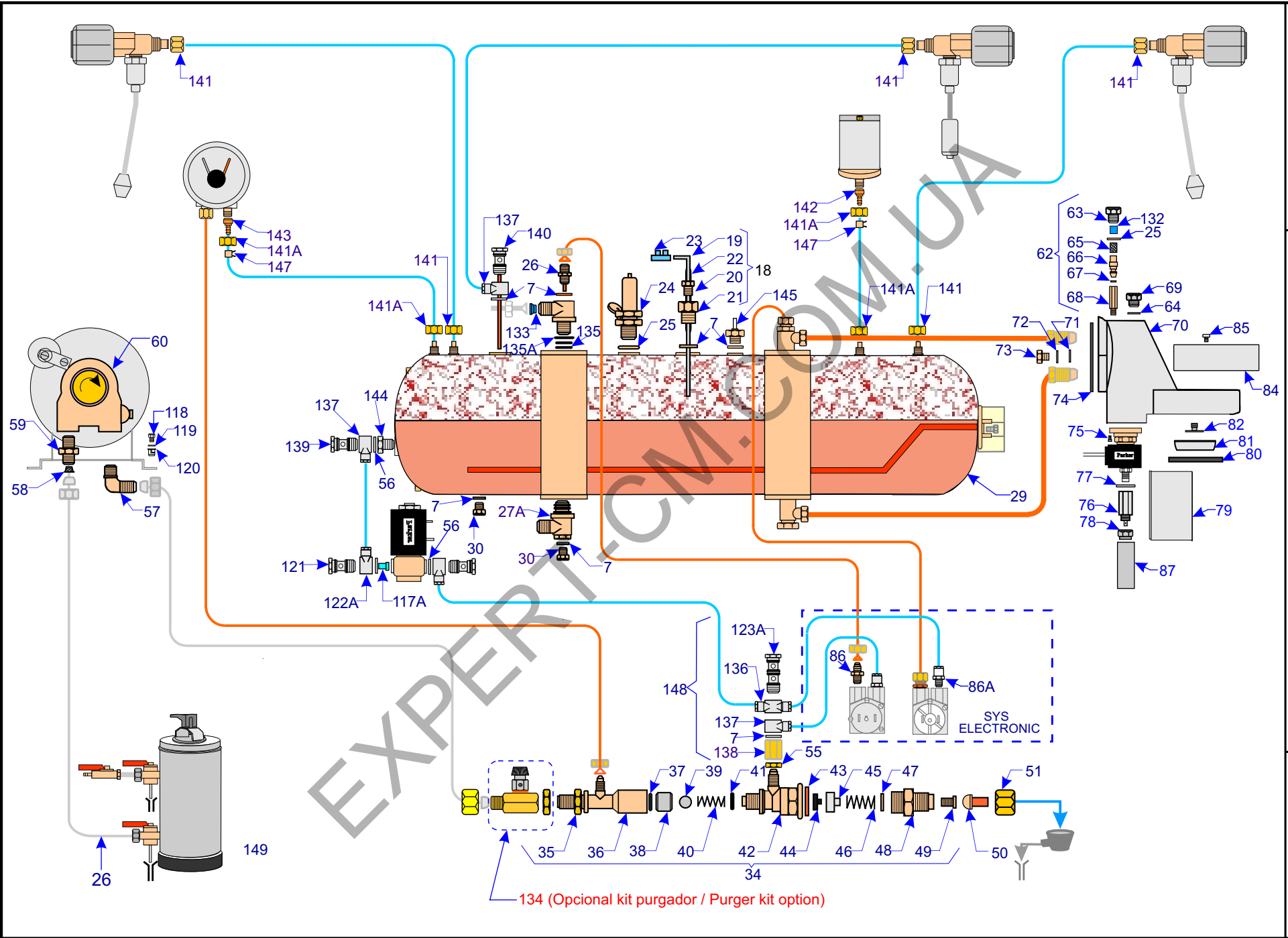

134 (Opcional kit purgador / Purger kit option)

Pos	DENOMINACION	DESCRIPTION	2 - 3GR	3 GR
7	Arandela de cobre	Washer	01626804	
18	Conjunto sonda	Level water fitting probe	0441/090816	
19	Sonda 123	Sensor 123	0441/090816A	
20	Prensa sonda	Sensor press	0441/090816D	
21	Racord sonda	Sensor fitting	0441/090816C	
22	Aislador sonda	Sensor standard-duty insulator	0441/090816B	
23	Regleta conexión	Level probe terminal	07389604	
24	Válvula de seguridad	7Pressure relief valve	08074701	
25	Arandela	Washer	07412208	
26	Racord de entrada (inyector)	Inlet fitting (injector)	08355000	
27A	Cjto. Racord tubo termico	Heat exchanger fitting assy	08469920	
29A	Caldera sin nivel optico	" without sight level	08491500	08491600
	" con nivel optico	" hout sight level	08501600	
30	Tapón	Heat exchanger drain plug	00225805	
34	Válvula retención / expansión	Check valve / relief valve assy	07843808	
35	Tuerca	Nut	04531505	
36	Cuerpo válvula retención	Check valve body	07922701	
37	Junta tórica	O-ring	07851900	
38	Casquillo	Cap	07851801	
39	Esfera	Ball	01832005	
40	Muelle	Spring	01720606	
41	Junta tórica	O-ring	07763204	
42	Cuerpo Válvula expansión	Pressure Rilief valve body	07851603	
43	Arandela	Washer	08506530	
44	Junta cierre	Gasket	01853704	
45	Casquillo	Cap	01853803	
46	Muelle	Spring	00109108	
47	Arandela	Washer	04711701	
48	Racord	Fitting	07468101	
49	Regulador muelle	Relief Valve orifice	07468408	
50	Niple especial	Nipple	08058901	
51	Tuerca niple 3/8	Nut	00011502	
55	Tuerca 1/4	Nut	04530600	
56	Arandela de cobre	Washer	07411600	
57	Racord	Fitting	08004418	
58	Filtro	Filter	08297900	
59	Racord	Fitting	0371/110103	
60	Bomba Fluid-o-tech	Pump Fluid-o-tech	07822109	
60	" Procon	" Procon	07822109-S	
62	Kit	Kit	NT 0029	
63	Tapón guía muelle	Spring square pin cap	07557200	
64	Arandela	Washer	07411507	
65	Filtro	Filter	08298700	
66	Inyector	Injector	08298800	
67	Junta tórica	O-ring	0371/040103	
68	Columna inyector	Injector column	08299000	
69	Tapón grupo	Group cap	02736403	
70	Cuerpo grupo	Group body	08427000	
71	Arandela	Washer	04333613	
72	Arandela grower	Washer	04316412	
73	Tornillo	Screw	04106217	
74	Junta posterior	Gasket	08305200	
75	Tornillo	Screw	05194402	
76	Columna descarga	Outlet column	08426400	
77	Arandela	Washer	08395300	
78	Tuerca tapa	Nut	08426500	
78	" " (Alta)	Nut (Tall)	08439700	
79	Tapa electroválvula	Group solenoid cover	08426600	
80	Junta portafiltro	Holder gasket	01652809	

POS.	DENOMINACION	DESCRIPTION	2-3GR.	3GR
81	Ducha	Shower	02610004	
81	" Castel	" Castel	02610020	
82	Rociador de agua	Traed group	02012904	
82	" " Castel	" " Castel	02012920	
83	Racord 1/8 x 1/4	Fitting	08341200	
84	Cubregrupos	Groups cover	08427100	
85	Tornillo M.4 x 8	Screw	04591300	
86	Racord abocardado	Fitting	02800704	
86A	Racord 6/4	Fitting	08499410	
87	Tubo descarga agua (Alta)	Water outlet tube (Tall)	08433410	
117A	Reductor entrada agua	Pressure reducer water inlet	08505510	
118	Tornillo c/exag.	Screw	04522405	
119	Arandela	Washer	0561/030127	
120	Tuerca enjaulada	Nut	0551/030136	
121	Tornillo simple 1/8"	Screw 1/8"	08504400	
122A	Anillo orientable 6/4 1/8" G.	Adjustable ring	08416010	
123A	Tornillo doble 1/4"	Double screw	08504510	
123B	" triple 1/4"	Triple screw		08504520
132	Tubo teflón 0.012mm.	Teflón 0.012 mm. tube	08441100	
133	Inyector (Ø interior 4,5 mm.)	Injector (Ø int 4,5 mm.)	08426700	
133	" (" 2,5 mm.)	" (" 2,5 mm.)	08426720	
134	Kit purgador (Opcional)	Purge kit (option)	08447700	
135	Junta tórica	O-ring	03060500	
135A	Junta torica 14 x 1,5	O-ring 14 x 1,5	08494710	
136	Anillo orientable doble 6/4	Double adjustable ring	08488510	
137	Anillo orientable 6/4	Adjustable ring	08462910	08462910
137A	Anillo orientable 8/6	Adjustable ring	08462900	
138	Racord 1/4 6/4	Fitting	08416600	
139	Cjto. Inyector tubo termico	Heat exchanger injector assy	08489500	
140	Cjto. Racors pesca	Inlet fitting assy	08489000	
141	Tuerca racord 8/6	Fitting nut	08488900	
141A	Tuerca racord 6/4	Fitting nut	08488910	
142	Espiga presostato	Connection fitting pressure switch	08489300	
143	" manómetro	Connection fitting pressure gauge	08489200	
144	Racord reductor	Fitting reducing	09000351	
145	Válvula antidepresión	Compensation valve body	09000953	
147	Abrazadera muelle Ø 6	Clip for tube	08503800	
148	Cjto. Colector	Collector complet	08492500	08492600

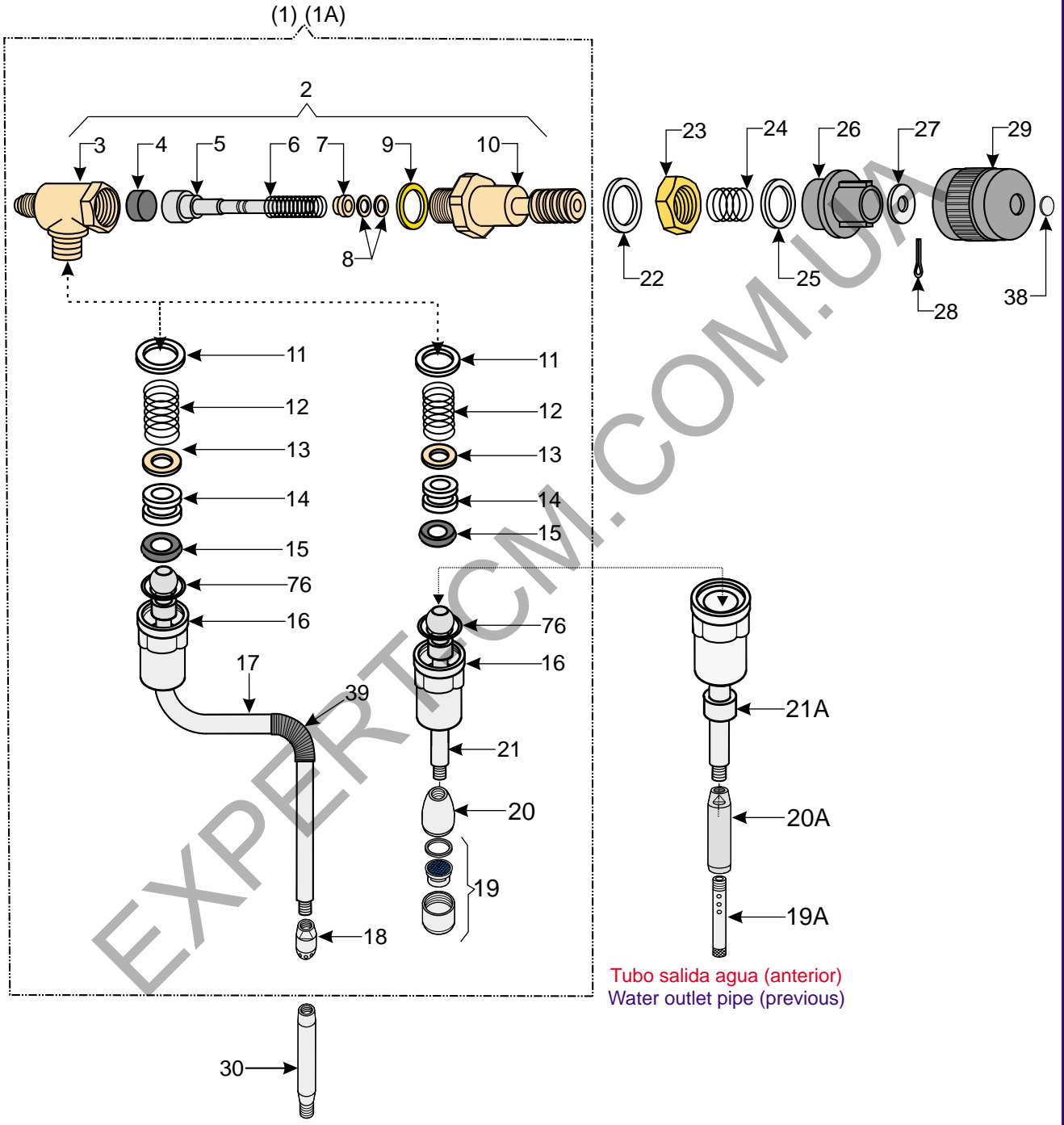

POS.	DENOMINACION	REFERENCE	DESCRIPTION
1	Cj. Grifo vapor	08165904	Steam tap assembly
1	“ “ “ UL E.U.	08165946	“ “ “ UL E.U.
1	“ “ “ Ottima	08493200	“ “ “ Ottima
1A	Cj. Grifo agua	08205908	Water tap assembly
1A	“ “ “ UL E.U.	08205916	“ “ “ UL E.U.
1A	“ “ “ COMPAC / XL UL E.U.	08166019	“ “ “ COMPAC / XL UL E.U.
1A	“ “ “ Ottima	08493300	“ “ “ Ottima
2	Grifo agua vapor	08204802	Steam water tap
2	“ “ “ Ottima	-	“ “ “ Ottima
3	Cuerpo grifo	08165003	Tap body
3	“ “ “ UL E.U.	08165011	“ “ “ UL E.U.
3	“ “ “ Ottima	08493100	“ “ “ Ottima
4	Taco cierre grifo	11181302	Rubber dowel
5	Cj. eje grifo	11156530	Tap rod assembly
6	Muelle	08389900	Spring
7	Casquillo	03001500	Buch
7	“ “ UL E.U.	03001518	“ “ UL E.U.
8	Junta tórica	02476703	Gasket
9	Junta metaloplastica	02455103	Metal-plastic join
10	Racord cuerpo	07358609	Body fitting
10	“ “ “ UL E.U.	07358617	“ “ “ UL E.U.
11	Arandela teflón	05132808	Washer
12	Muelle rotula	08165300	Hinge joint spring
13	Arandela	08165508	Washer
14	Tope rotula	08397800	Hinge joint stop
15	Junta tórica	07763204	Gasket
16	Tuerca rotula	08165130	Hinge joint Nut
17	Tubo salida vapor	08165722	Steam outlet tube
18	Difusor vapor	08207400	Steam shower
19	Salida infusiones malla	09000325	Water shower
19A	Salida infusiones	08207607	“ “
20	Cuerpo ducha	09415200	Shower body
20A	“ “	08207506	“ “
21	Rotula agua caliente	08333010	Water hot hinge joint
21	“ “ “ COMPAC / XL UL E.U.	08304500	“ “ “ COMPAC / XL UL E.U.
21A	Rotula agua caliente	08206013	Water hot hinge joint
22	Arandela	07412509	Washer
23	Tuerca	05060680	Nut
24	Muelle	08018707	Spring
25	Arandela	07413107	Washer
26	Casquillo pomo	08185804	Handle cap
27	Arandela	07414501	Washer
28	Pasador	05160007	Pin
29	Pomo grifo	08335400	Tap buch
30	Suplemento tubo vapor (Opcional)	08261109	Steam tube supplement (Option)
38	Tapeta vapor	08147804	Steam lid
38	Tapeta agua	08147903	Hot water lid
39	Protector tubo vapor	08339000	Steam protector pipe
76	Inserto tuerca rotula	08479900	Hinge joint nut Insert

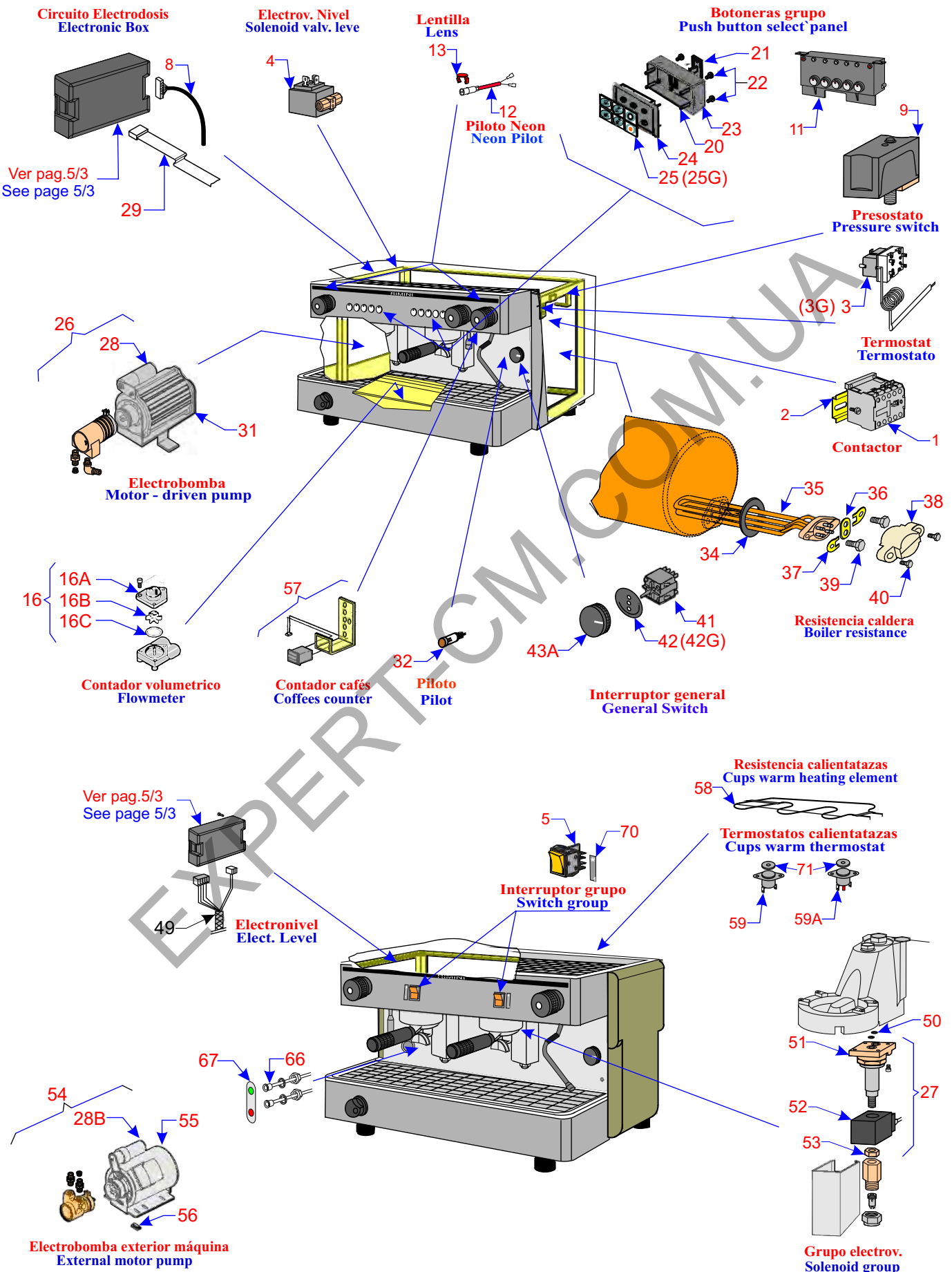

Pos	DENOMINACION	DESCRIPTION	1GR.	2GR	Ottima 3 GR.	COMPAC	XL
49	Cableado electronivel	Elect. Level cable	08313700	08313700			
50	Junta tórica	O-ring	03061009	03061009	03061009	03061009	03061009
51	Electrov.sin bobina PARKER	Solenoid sans bobine PARKER	01182302	01182302	01182302	01182302	01182302
51	" " " O.D.E	" " " O.D.E.	01182500	01182500	01182500	01182500	01182500
52	Bobina 230V.50/60Hz. PARKER	Coil 230 V. 50/60 Hz. PARKER	01181008	01181008	01181008	01181008	01181008
52	" 115V.50/60 Hz. PARKER	" 115 V. 50/60 Hz. PARKER	08124300	08124300		08124300	08124300
52	" 230 V.50/60 Hz. O.D.E	" 230 V. 50/60 Hz. O-D.E.	01182609	01182609	01182609	01182609	01182609
52	" 115 V. 50/60 Hz. O.D.E.	" 115 V. 50/60 Hz. O.D.E.	01182807	01182807		01182807	01182807
53	Tuerca	Nut	04725106	04725106		04725106	04725106
54	Cj.Electrobo230V50Hz. Ex.maq	External motor pump 230V.50Hz.	NT0001	NT0001	NT0001	NT0001	NT0001
54	" " 115V. ext. maquina	" " " 115V.	NT0101	NT0101		NT0101	NT0101
54	" " 230V.60Hz. Ex maq	" " " 230V.60Hz.	NT0201	NT0201	NT0201	NT0201	NT0201
55	Motor 230V. 50 Hz.	Motor 230V. 50 Hz.	08083008	08083008	0808308	08083008	08083008
55	" 115V. 60 Hz.	" 115V. 60 Hz.	08082802	08082802		08082802	08082802
55	" 230V. 60Hz.	" 230V. 60Hz.	08083107	08083107	08083107	08083107	08083107
56	Pié bomba	Motor foot	08083206	08083206	08083206	08083206	08083206
57	Kit (Contador cafés)	Kit (Coffees counter)	NT0913	NT0913	NT0913	NT0913	NT0913
58	Resistencia calentatazas	Cups warm heating element		08420300			
59	Termostato calentatazas	Cups warm thermostat		08368400			
59A	" " rearme	" " " rearm		08368410			
66	Cjto. led	Level led	08456900	08456900			
67	Etiqueta nivel	Level sticker	08456700	08456700			
70	Etiqueta adhesiva paro marcha * - 1	Sticker on - off * - 1	08443300	08443300			
71	Conductor de calor	Heat conduction		08478900			

CABLEADO / REGULAR LAY

02217016	Cable a electrobomba exterior maquina	Out machine motor-driven pump cable
08306700	Cable Instalación Interruptor general	Installation general witch cable
08306710	" " " " UL E.U.	" " " " UL E.U.
08306770	Cable instalación Interruptor general (115 V.)	Installation general witch cable (115 V.)
08306760	" " " " resistencia + calentatazas	" " " " heating elementg + cups warm
08324500	" " " " 0-1 1Gr. GENOVA	" " " " 0-1 1Gr. (GENOVA)
08325800	" " " " 1 - 2 Gr. Monofasico	" " " " 1 - 2 Gr. Single Phase
08343200	Cable general electronica 1 Gr.	Electronic general cable 1 Gr.
08451200	" " " " 1 Gr. UL E.U.	" " " " 1 Gr. UL E.U.
08310400	" " " " 2 Gr.	" " " " 2 Gr.
08310500	" " " " 3 Gr. Ottima	" " " " 3 Gr. Ottima
08424300	" " " " 2 Gr. UL E.U. / XL	" " " " 2 Gr. UL E.U. / XL
08480700	" " " " 2 Gr. COMPAC / XL	" " " " 2 Gr. COMPAC / XL
08313700	Cable electronivel	Elect. Level cable
08315800	Cable interruptores pulser 1 Gr.	Pulser switchs cable 1 Gr.
08315900	" " " " 2 Gr.	" " " " 2 Gr.
08351000	Cable botonera 1 Gr.	Panel push button 1 Gr.
08351100	" " " " 2 Gr.	" " " " 2Gr.
08351200	" " " " 3 Gr. Ottima	" " " " 3 Gr. Ottima
08316900	Cable contactor presostato UL E.U.	Contactore pressure switch cable UL E.U.
0651/060117	Cable entrada red UL E.U.	Red inlet cable UL E.U.
08559200	Cable entrada red (115 V.)	Red inlet cable (115 V.)
08505400	Cable puente piloto interruptor general	Bridge cable, pilot
08506400	Cable conexión piloto nivel 115 UL	Level pilot connection cable 115 UL
08368310	Cable resistencia calentatazas	Heating element cable
07389604	Regleta nivel sonda	Level probe terminal
07832405	Brida sujeción cable instalación	Installation clamp cable
08158206	Brida sujeción cables	Cable clamp
07896301	Brida lazo 2225-1	Clamp 2225-1
09000265	Regleta (115 V.)	Terminal (115 V.)

MODEL	TIPO MAQUINA TYPE MACHINE	TIPO UNIDAD ELECTRONICA TYPE MAINBOARD	REFERENCE			OBSERVATIONS	
			115 V.	230 V.	200 V.		
RIMINI NERA GIULIETA CAPRI COMPAC XL GENOVA IT4 ARIANNE ARIETE ARIETE KB-200 KB-2000 F3 G6 / V6 OTTIMA	ELECTRONIC ELECTRONIC ELECTRONIC ELECTRONIC ELECTRONIC ELECTRONIC ELECTRONIC ELECTRONIC ELECTRONIC DISPLAY ELECTRONIC DISPLAY ELECTRONIC ELECTRONIC ELECTRONIC	STANDARD- STANDARD+C/TAZAS – CUP WARMER STANDARD+CAPPU. UL – E.E.U.U.	08289605 08220501 08524810	08280307 08363900 08220303 08524610	08524900	AUTO TEST	
F3	DISPLAY C/ nivel optico With sight level	DISPLAY+C/TAZAS – CUP WARMER DISPLAY+CAPPU.		08371720 08371740			
F3	DISPLAY C/ led de nivel With level led	DISPLAY+C/TAZAS – CUP WARMER DISPLAY+CAPPU.		08455700			
G6 / V6	DISPLAY GROUPTRONIC® GROUPTRONIC®	DISPLAY+C/TAZAS - CUP WARMER REGULACION Tª GRUPOS GROUP TEMPERATURE REGULATION	08414500				TRANSF. EXTERIOR
F3	SEMIAUTOMATIC	SEMIAUTOMATIC SEMIAUTOMATICAS+C/TAZAS SEMIAUTOMATIC+CUP WARMER		08351500 08363800			
TODOS - ALL	SEMIAUTOMATIC	NIVEL ELECTRONICO ELECTRONIC LEVEL	08386810	08386800			
DIAMOND AUSTRALIA	DISPLAY GROUPTRONIC®	DISPLAY + C/TAZAS- CUP WARMER		08455710			TRANSF. 12 V.

NOTA: SE RECUERDA QUE, EN LAS MAQUINAS QUE INCORPORAN MEZCLADOR DE AGUA CALIENTE/FRIA, DEBERAN DE ACTIVAR DICHA PRESTACION CUANDO SUSTITUYAN LA U. ELECTRÓNICA PROCEDENTE DE RECAMBIOS

NOTE: IN THE MACHINES THAT INCORPORATE THE WATER MIXER, WHEN YOU REPLACE THE MAINBOARD COMING FROM SPARE PARTS, YOU WILL HAVE TO ACTIVATE THIS OPTION.

ACTIVACION / DESACTIVACION:

- 1º.- PONER INTERRUPTOR GENERAL A "0"
- 2º.- PULSAR SOBRE EL BOTON DE INFUSIONES, Y SIN SOLTAR PONER EL INTERRUPTOR GRAL. EN "1", ESPERAR 4-5 SEGUNDOS
- 3º.- SOLTAR EL BOTON DE INFUSIONES

ACTIVATION / DEACTIVATION:

- 1º.- GENERAL SWITCH TO POSITION "0"
- 2º.- PRESS THE HOT WATER BUTTON AND HOLD, SIMULTANEOUSLY TURN GENERAL SWITCH TO POSITION 1 AND WAIT APROX. 5 SEC
- 3º.- RELEASE THE HOT WATER BUTTON

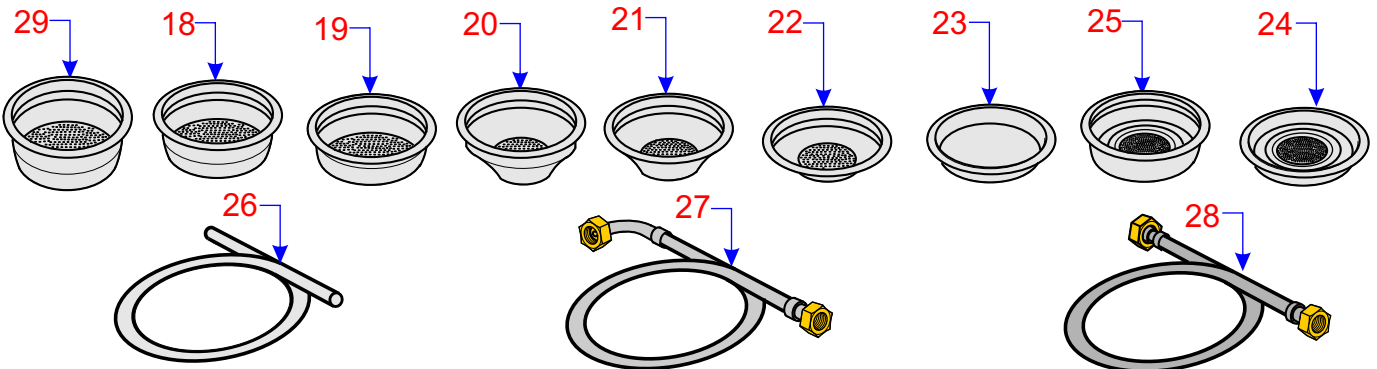
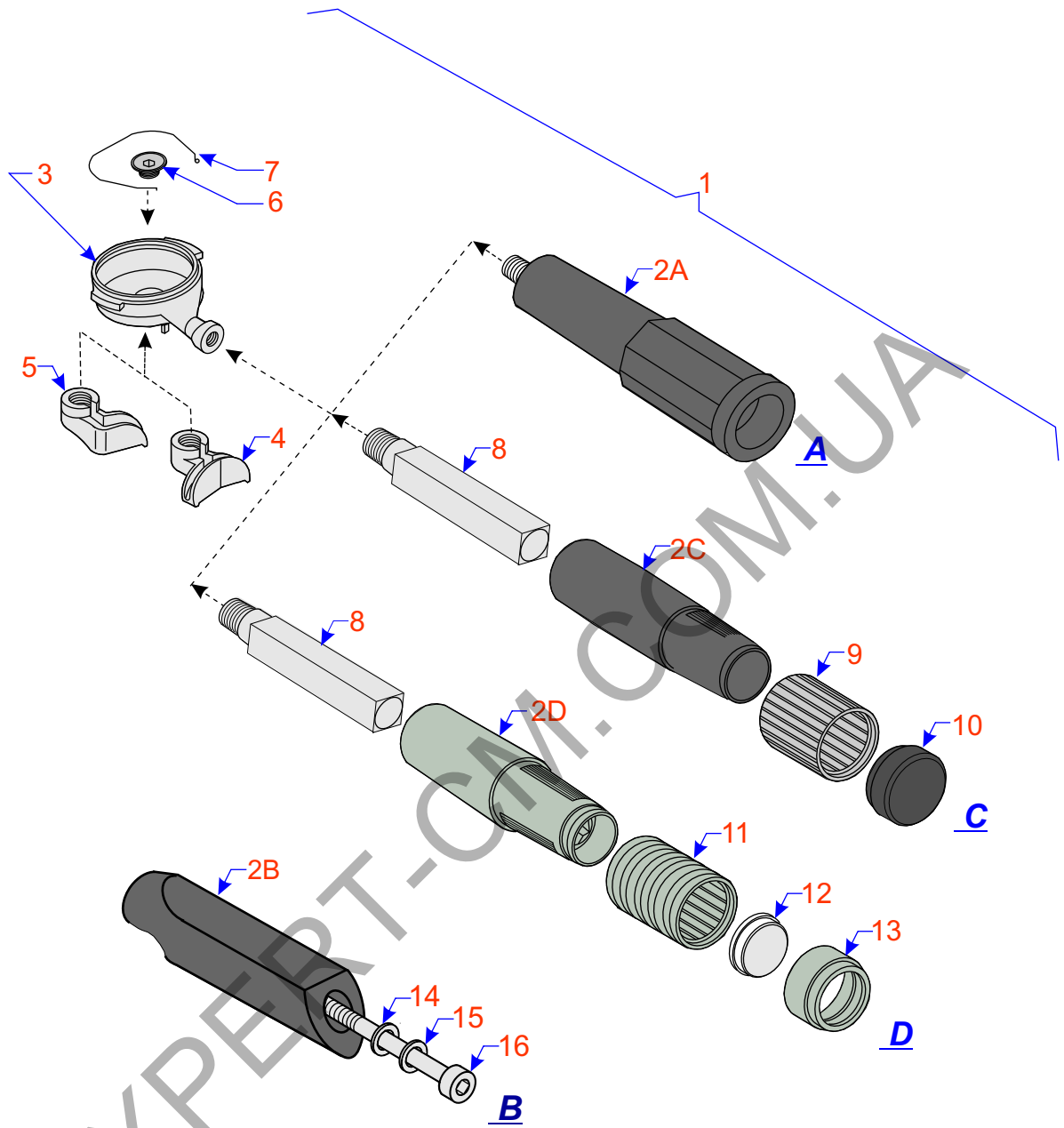

POS	DENOMINACION	REFERENCE	DESCRIPTION
1A	Cj. Porta filtros inclinado 1 café	08486500	Filter holder assy, 1 coffee (Inclined)
1A	" " " " 2 cafés	08486520	" " " 2 coffee "
1A	Cj. Porta filtros inclinado 1 café LUX	08486510	Filter holder assy, 1 coffee LUX (Inclined)
1A	" " " " 2 cafés LUX	08486530	" " " 2 coffee LUX "
1C	Cj. Porta filtros inclinado 1 café	08485800	Filter holder assy, 1 coffee (Inclined)
1C	" " " " 1 café (ETL)	08508900	" " " 1 coffee (ETL) "
1C	" " " " 2 cafés	08485900	" " " , 2 coffee "
1C	" " " " Sin pitorro	08486700	" " " without dispense nozzle (Inclined)
1D	Cj. Porta filtros inclinado 1 café Gris	08486000	Filter holder assy , 1 coffee Gray (Inclined)
1D	" " " " 1 café Negro	08486010	" " " 1 coffee Black (Inclined)
1D	Cj. Porta filtros inclinado 2 cafés Gris	08486100	Filter holder assy , 2 coffee Gray (Inclined)
1D	" " " " 2 cafés Negro	08486110	" " " 2 coffee Black "
2A	Mango porta filtro	07821705	Filter holder handle
2B	Mango porta filtro Negro	08103600	Filter holder handle Black
2B	" " Gris	08103618	" " " Gray
2C	Mango porta filtros	08335700	Filter holder handle
2D	Mango porta filtros Gris	08412000	Filter holder handle Gray
2D	" " " Negro	08412010	" " " Black
3	Cuerpo porta filtros inclinado	08480050	Filter holder body (Inclinado)
3	" " " " (ETL)	08509000	" " " " (ETL)
3	" " " " LUX	08480060	" " " " LUX
3	" " " " Sin pitorro	08480080	" " " without dispense nozzle (Inclined)
4	Pitorro 2 cafés	08366750	Dispense nozzle 2 coffee
4	" " LUX	08366760	" " 2 coffee LUX
5	Pitorro 1 café	08366650	Dispense nozzle 1 coffee
5	" " LUX	08366660	" " 1 coffee LUX
6	Tornillo pitorro	08480100	Dispense nozzle screw
6	" " LUX	08480110	" " " LUX
7	Muelle	11214301	Spring
8	Eje mando porta filtros	08335800	Holder handle rod
9	Goma mango porta filtros	08335900	Holder handle protector
10	Tapa mango porta filtros	08336000	Holder handle sticker
11	Embellecedor mango Gris	08412100	Holder handle protector Gray
11	" " Negro	08412110	" " " black
12	Tapeta mango porta filtros	08412300	Holder handle sticker
13	Tapa mango porta filtros Gris	08412200	Holder handle sticker Gray
13	" " " Negro	08412210	" " " back
14	Arandela	07568702	Washer
15	Arandela dentada	07414300	Washer
16	Tornillo allen	05193800	Screw
18	Cacillo 2 cafés grande	02199404	Filter 2 coffee large
19	" 2 cafés pequeño	01657501	" 2 coffee little
20	Cacillo 1 café grande	02183002	Filter 1 coffee large
21	" 1 café pequeño	01441807	" 1 coffee little
22	" 1 café pequeño especial	08207102	" 1 coffee little special
23	Cacillo ciego	02190205	Blind filter
24	Cacillo monodosis 1 café castel	08365000	Filter 1 coffee Castel
25	" " 2 cafés castel	08365100	" 2 coffee Castel
26	Tubo desagüe	08020703	Outlet pipe
27	Tubo entrada 1600 mm.	0551/050112	Water inlet hose 3/8 – 1600 mm.
28	Tubo flexible 710 mm.	0571/050108	" " " - 710 mm.
29	Cacillo 2 cafés (ETL)	08509100	Filter 2 coffee (ETL)

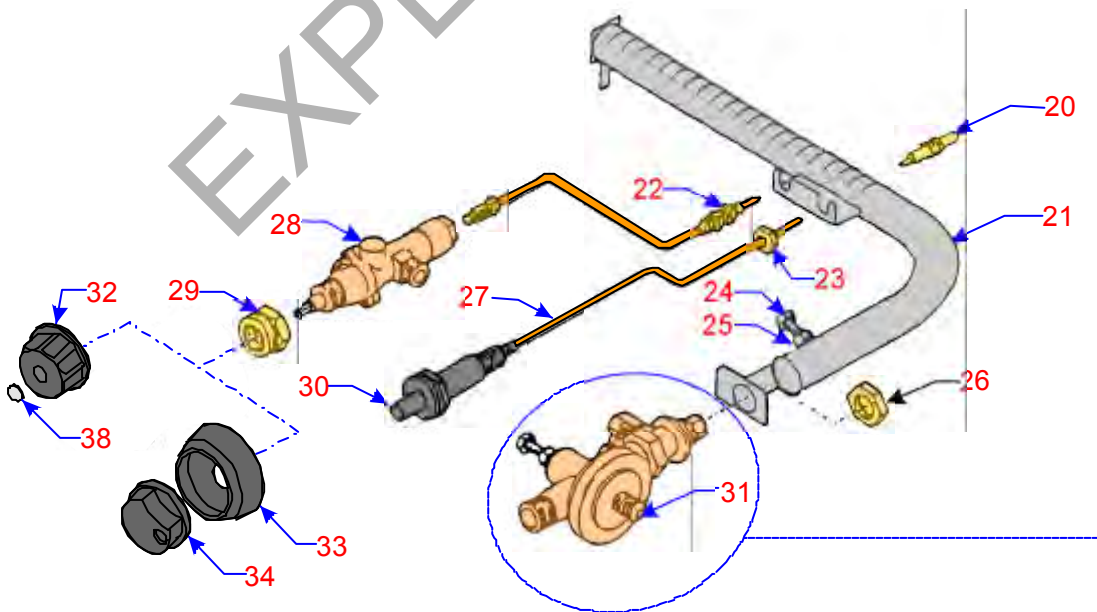
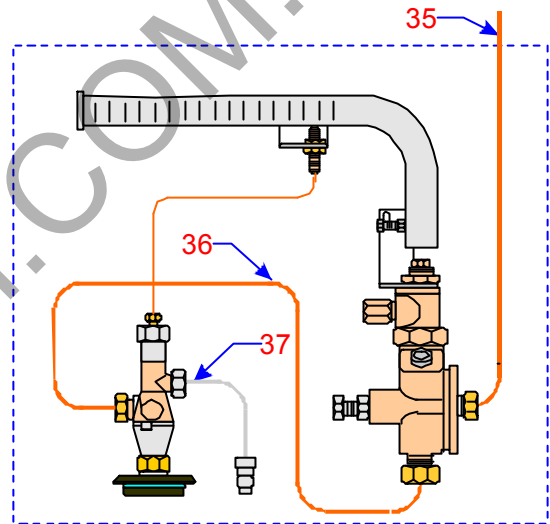
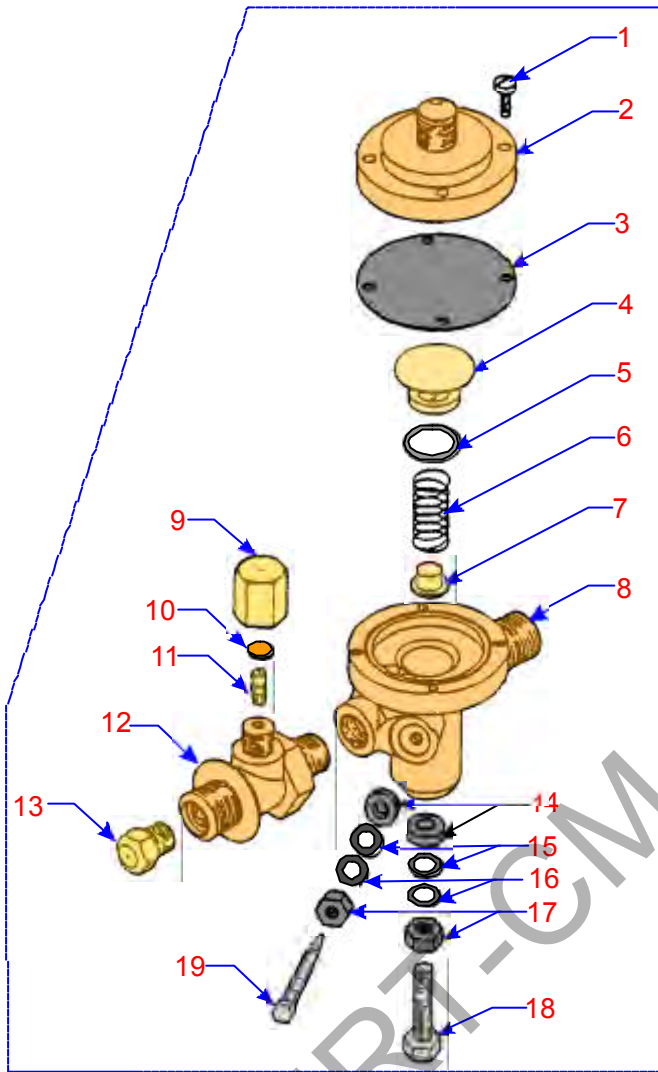

POS.	DENOMINACION	DESCRIPTION	REFERENCE
1	Tornillo	Screw	04134912
2	Tapa cuerpo automático	Automatic element cap	01742717
3	Membrana	Membrane	00290601
4	Cuerpo cierre	Closing body	00290304
5	Junta tórica	Gasket	01826502
6	Muelle	Spring	00290403
7	Guía del muelle	Spring square pin	00290502
8	Cuerpo automático gas	Automatic gas element	01742618
9	Tuerca de cierre	Close nut	08049207
10	Disco de cierre	Close disk	07413909
11	Inyector toma presión	Pressure injector	08057301
12	Racord porta inyector	Injector Fitting	08057202
13	Inyector	Blind injector (see table for different styles)	Ver tabla
14	Arandela junta	Gasket	02662104
15	Arandela	Washer	04715801
16	Arandela dentada	Washer	04318309
17	Tuerca	Nut	04127817
18	Tornillo	Screw	04104816
19	Tornillo de regulación	Regulator screw	02509909
20	Bujía	Lighter stem	0561/060103
21	Quemador 1Gr.	1 Gr. Modern burner	07917920
21	Quemador 2 Gr.	2 Gr. Modern burner	07850712
22	Termopar	Thermocouple	07824105
23	Tuerca	Washer	04339412
24	Tornillo de M.4	Screw	04101217
25	Tuerca de M.4	Nut	04127619
26	Tuerca	Nut	04531505
27	Cable bujía	Stem cable	07859903
28	Grifo gas	Gas tap	07451610
29	Tuerca grifo gas	Tap nut	08099300
30	Encendedor	Gas lighter	07858400
31	Cj. Automático gas	Gas automatic whole	08049306
32	Mando gas (M – Ital.)	Gas handle	07678700
33	Embellecedor mando	Water handle embellishment	08099500
34	Mando gas (F / G)	Gas handle	08183311
35	Tubo caldera automático gas	Tube automatic gas tank	08357900
36	Tubo grifo automático gas 1 Gr.	Tube automatic gas tap 1 Gr.	08321000
36	Tubo grifo automático gas 2 Gr.	Tube automatic gas tap 2 Gr.	08358000
37	Tubo entrada gas	Tube gas inlet	08320900
38	Tapeta gas (M)	Gas lid (M)	08099800
38	“ “ (I)	“ “ (I)	08276900

TABLA DE INYECTORES

Gr.	GLP -PROPANO-BUTANO		GAS NATURAL	
	CODIGO	Ø mm.	CODIGO	Ø mm.
1	08047706	0,5	08048100	0,9
2	08047805	0,75	08048209	1,15

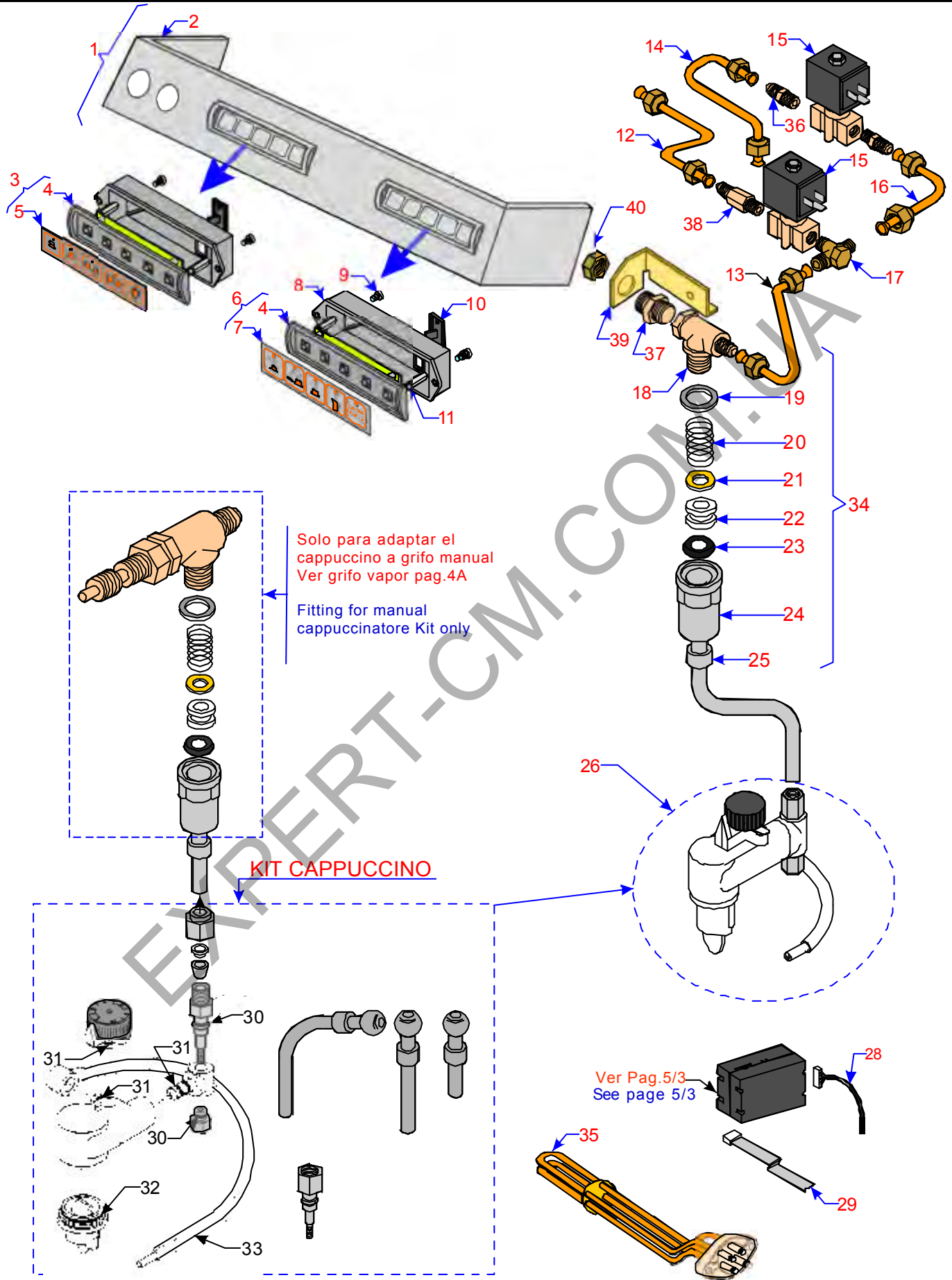

POS	DENOMINACION	DESCRIPTION	Stand.1-2-GR	Stand.1 GR	Stand.2GR
1	Cj. Perfil cappuccino	Compleat front		08274820	
2	Perfil Cappuccino	Front cappuccino		08268500	
3	Cj botonera	Compleat bush button	08109400		
4	Circuito botonera	Bush button circuit	08211906		
5	Adhesivo botonera	Bush button Adhesive	08109600		
6	Cj. Botonera cappuccino	Compleat bush button capp.	08209603		
7	Adhesivo botonera cappu.	Bush button adhesive capp.	08209702		
8	Caja botonera	Bush button switch box	08109800		
9	Tornillo C/cilind. M.3 x 6	Screw	04550505		
10	Prensa cable	Cable pressing	08109900		
11	Separador	Hx. Hd. Screw	08079402		
12	Tubo caldera electrov. capp.	Boiler water tube		08358900	
13	Tubo Electr. cappuccinatore	Cappuccino solenoid tube	08359200		
14	Tubo vapor	Steam Tube		08350300	
15	Electroval. cappuccino 230 V	Solenoid cappuccino 230 V	0611/060113		
16	Tubo electrov. a electrovav.	Solenoid tube		08350500	
17	Racord 1/8 x 1/4	Fitting	08341200		
18	Cuerpo grifo	For stopcock body	081650003		
19	Junta	Gasket	05132808		
20	Muelle rotula	Spring	08165300		
21	Arandela rotula	Washer	08165508		
22	Tope rotula	Stop	08165201		
23	Junta torica	O-ring	07763204		
24	Tuerca rotula	Nut	08165110		
25	Tubo salida agua	Water outlet pipe	08341400		
26	Cappuccinatore	Cappuccinatore	NT0026		
28	Cable general	Main cable		08358300	
29	Cable botonera	Panel push of button cable		08312400	
30	Junta tórica	O-ring	03061009		
31	Junta tórica	O-ring	08231300		
32	Junta tórica	O-ring	08231409		
33	Tubo silicona 6 x 9	Clear tubing 6 * 9	67613609063		
34	Cj. Grifo cappuccino	Tap cappuccino complet	08341300		
35	Resistencia 230 V.	Tank heater kit 230 V.		08024804 3000w.	
36	Racord 1/8"	Fitting	07466501		
37	Racord cuerpo grifo	Tap body fitting	08340600		
39	Soporte grifo cappuccino	Tap cappuccino support	08362900		
40	Tuerca	Nut	05050680		
	Cable instal. interruptor general	Installation cable	08306700		